



Manhole Slab Forming Systems



Slab Forms Engineered to Last

- Slab Top
- Transition Slab
- Base Slab
- Wetcast Applications

Heavy steel construction designed for strength, durability and performance

Afinitas is known for bringing together the top engineering and manufacturing expertise in the industry to build best-in-class precast forming systems. Our wide range of quality products are backed by knowledgeable and responsive customer sales and manufacturing team members who are there to assist you throughout the life of your form. And to that point, our forms are built to last. We combine heavy-duty steel with an innovative approach to manufacturing that will ensure we can help you take your business where you want to grow.

Manhole products are a core competency of the Afinitas team. We have been trusted for decades to engineer forms for a wide variety of manhole products, including:

- Eccentric Cone Forms
- Concentric Cone Forms
- Slap Top, Transition Slab, Base Slab Forms
- Extended and Straight Base Forms
- Riser Forms
- Drop Base and Drop Riser Forms
- Single Pour Grade Ring Forms
- Battery Grade Ring Forms
- Manhole Joint Rings



Manhole Cone Form



Manhole Base Form



Manhole Riser Form



Afinitas is your source
for Wetcast Forming Systems.

Contact our team at
+1 641-394-4111
or email rfq@afinitas.com

Slab Top

Slab tops are used in applications where a manhole is needed to access underground utilities, such as sewer and water lines. Strength is of the utmost importance. We engineer our slab top forms to exacting standards to ensure your manhole products are simple to install and safe, reliable, and durable. Our designs cover all sizes and styles.

The Afinitas Advantage

- Diameters from 36" through 144"
- Two-piece design with toggle clamps, seam bars and alignment pins
- Mechanical collapsing inner core (available loose or bolted and in several diameters)
- Groove pallet with ID notch for bolt down cover plate



Slab Top Form

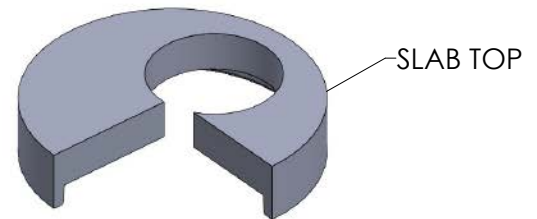

End Product

Cover Plate Bolted to the Groove Pallet

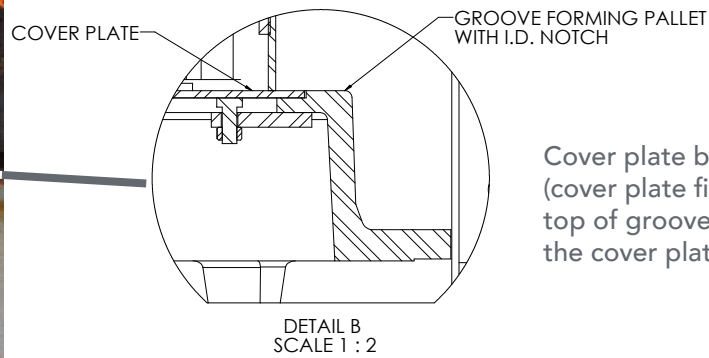

Cover plate bolted to the groove pallet (cover plate fits inside joint ring, flush with top of groove pallet). No need to retrieve the cover plate during strip out.

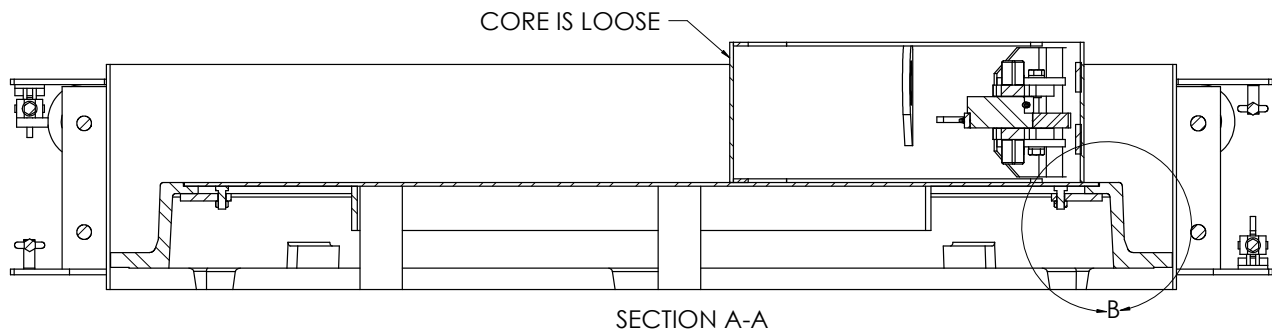

Transition Manhole Slab

Transition manhole slabs are used in a variety of applications, including roadway construction, sewer and drainage projects, landscaping and stormwater management projects. These slabs offer a number of advantages over traditional methods of constructing manholes. They are faster and easier to install, which can save time and money on the project. They also provide a more accurate and consistent finish, which can improve the overall appearance of the project. Plus they are very durable. We can provide formwork that will further enhance the speed and efficiency of your project in a variety of sizes and shapes to meet the specific needs of your project.



Transition Slab

The Afinitas Advantage

- Diameters from 60" through 144"
- Two-piece design with toggle clamps, seam bars and alignment pins
- Mechanical collapsing inner core (available loose or bolted and in several diameters)
- Groove pallet with ID notch for bolt down cover plate
- Tongue forming, open top header with (4) lifting eyes and core hangers (header to locate off core)

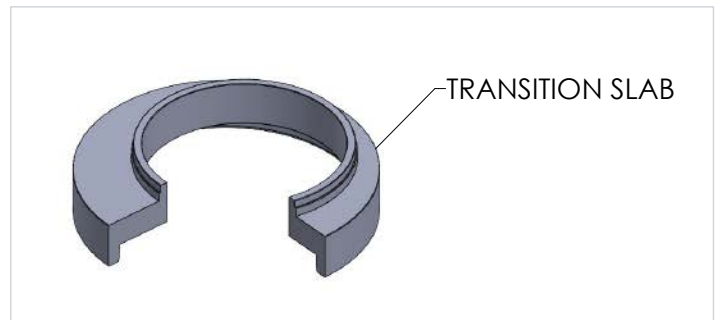

End Product

Transition Manhole Slab Form Design

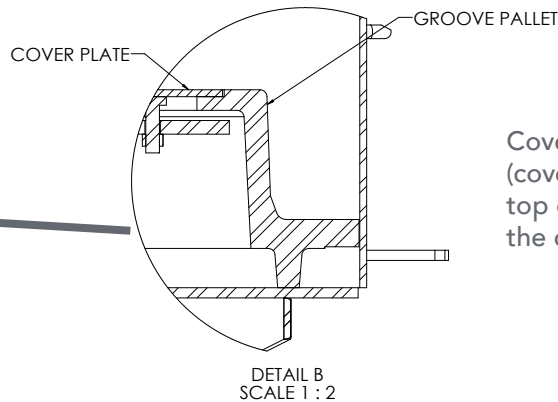

Cover plate bolted to the groove pallet (cover plate fits inside joint ring, flush with top of groove pallet). No need to retrieve the cover plate during strip out.

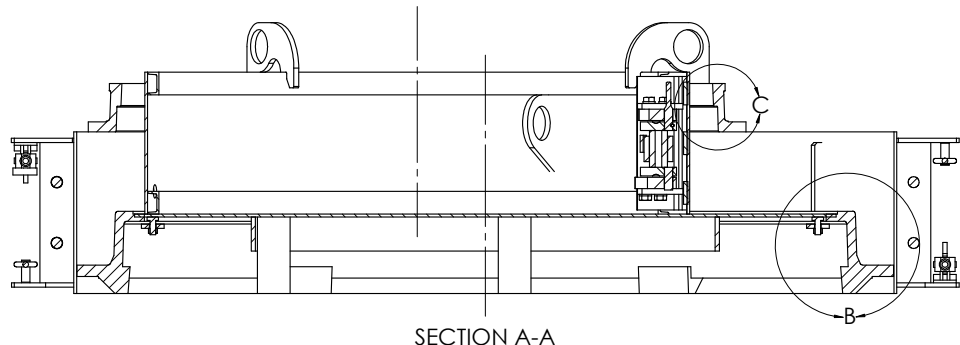
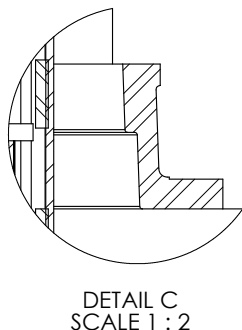

Base Slab

We manufacture forms to accommodate bases that are poured monolithically or poured as a separate base. An invert or flow channel can also be poured into the base section if required. Our systems provide a smooth surface for manhole rings to sit on, which helps create a watertight seal.

The Afinitas Advantage

- Diameters from 24" through 144"
- Two-piece design with toggle clamps, seam bars and alignment pins

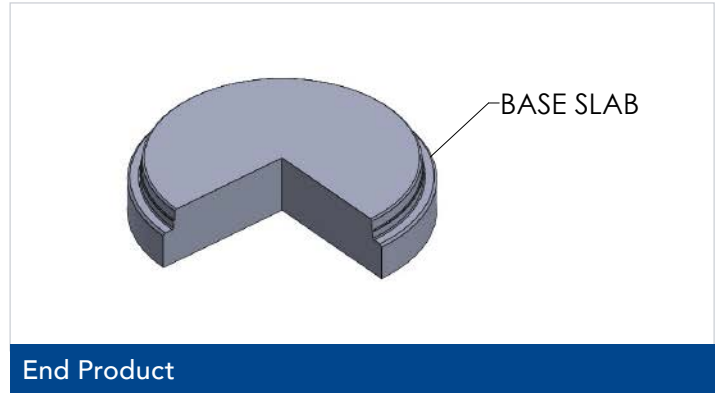

Base Slab Form Design

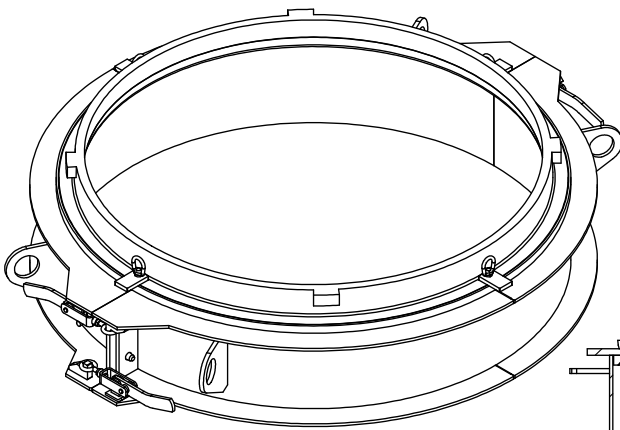

Tongue forming, open top header with (4) lifting eyes and form tabs (header to locate off form).

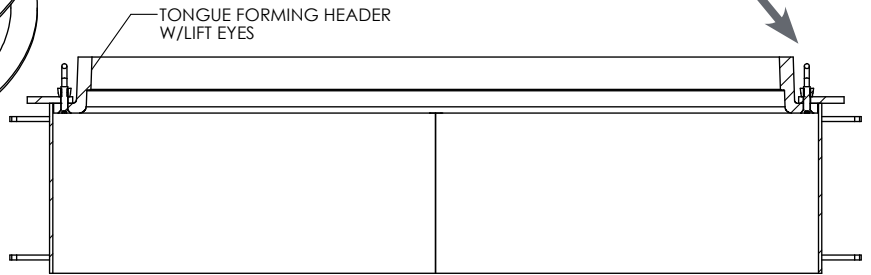

SECTION B-B



Why Choose A "Roll Back" Option?

With the Roll Back form the form doors are manually rolled open/close. The manufacturing team does not have to handle the outer form with an overhead hoist. This makes the process simpler and safer.



Roll Back Form Doors with Seam Flat Bars, Seam Alignment Pins and Pull Handles

Roll Back Option Design

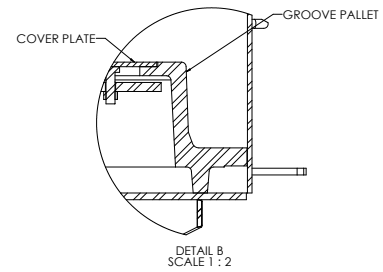
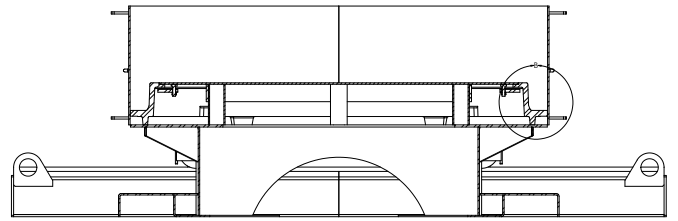

Other Options Available



Vibrator mounting brackets (several make/models to choose from). Air or electric vibrators are also available.



Manual step pin assemblies or cast-in plastic break-off step inserts. We also offer manual lift hole blockout pins or lift insert assemblies (several make/models to choose from).



One Piece Form Design



Slab Top, Transition Slab, Base Slab

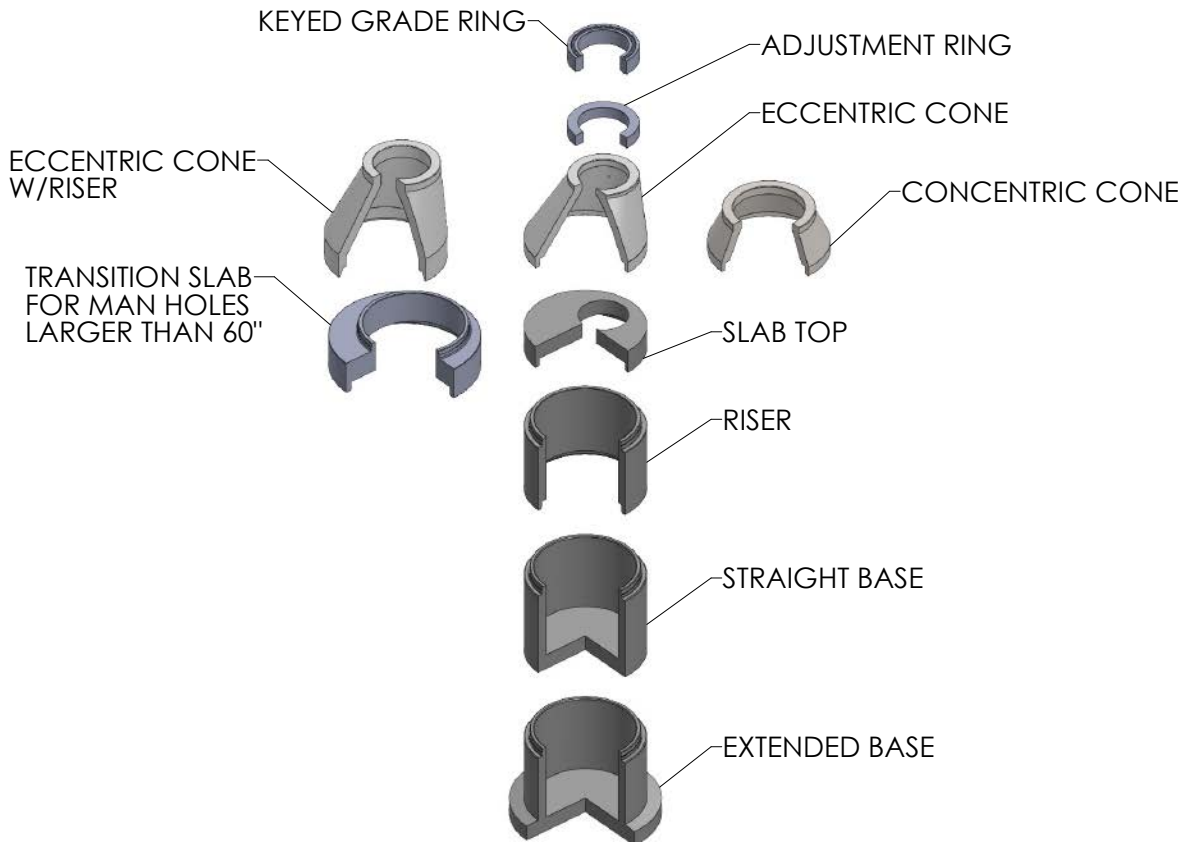
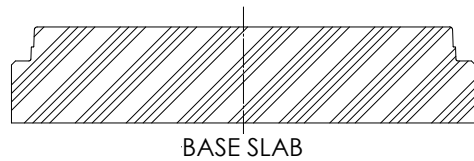
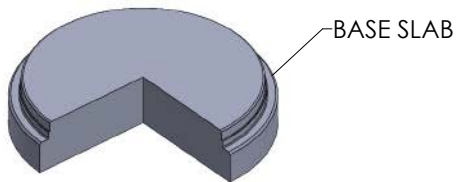
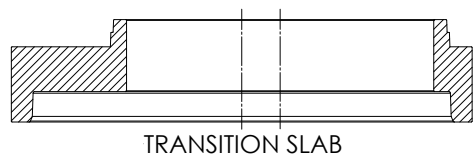
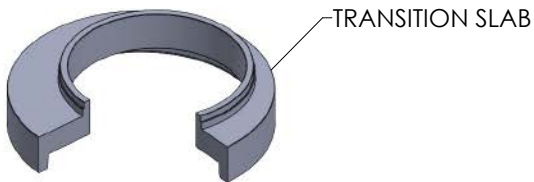
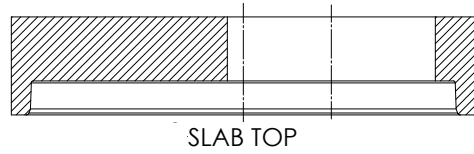
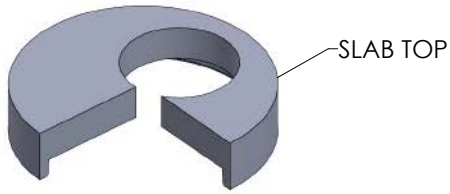



Manhole Slab Forming Systems

Intelligent Infrastructure Solutions

Equipment & Automation



Concrete Accessories

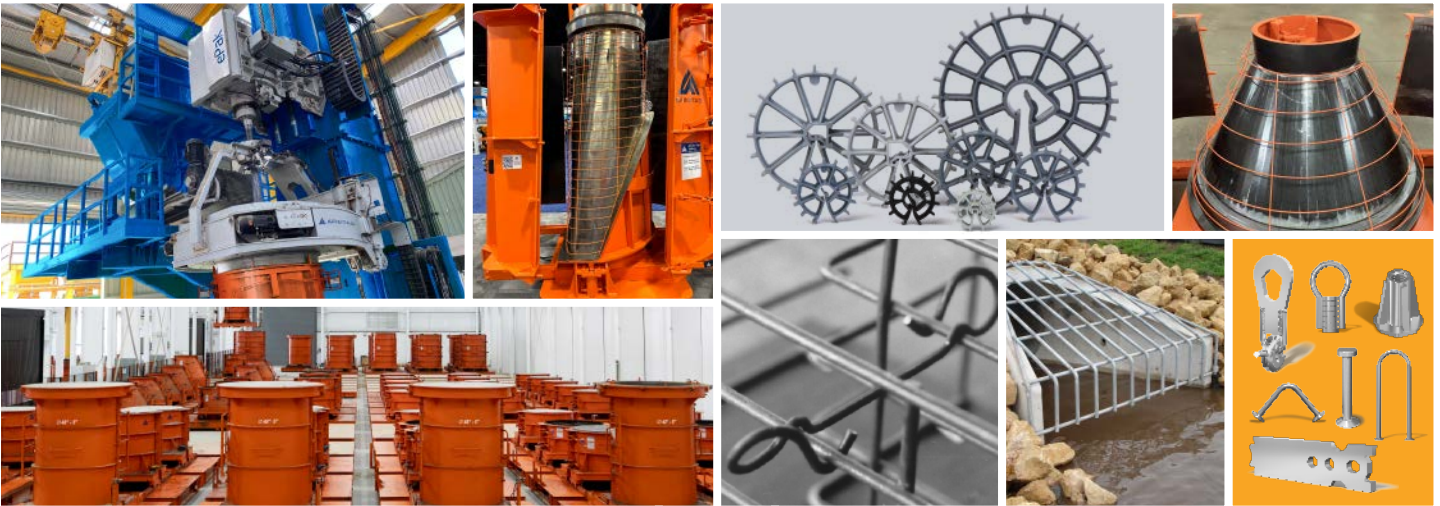

Visit www.afinitas.com to learn more.

Afinitas Equipment & Automation Division

506 S. Wapello St., Mediapolis, Iowa 52637

**Machines/Automation/
Drycast Forms**

Phone: +1 319-394-3197
info@afinitas.com

Wetcast Forms

Phone: +1 641-394-4111
rfq@afinitas.com

Parts

Phone: +1 319-394-2240
aftermarket-na@afinitas.com

Service

Phone: +1 319-394-2270
service-na@afinitas.com



Intelligent Infrastructure Solutions

Afinitas is a global, comprehensive and customer-oriented equipment, automation, forming, accessories and services platform for precast concrete and infrastructural products.

Afinitas Equipment and Automation Division:
+1 641-394-4111 | rfq@afinitas.com | www.afinitas.com