



Manhole Base Forming Systems



Base Forms Engineered to Last

- Wetcast
- Straight Base
- Extended Base

Heavy steel construction designed for strength, durability and performance

Afinitas is known for bringing together the top engineering and manufacturing expertise in the industry to build best-in-class precast forming systems. Our wide range of quality products are backed by knowledgeable and responsive customer sales and manufacturing team members who are there to assist you throughout the life of your form. And to that point, our forms are built to last. We combine heavy-duty steel with an innovative approach to manufacturing that will ensure we can help you take your business where you want to grow.

Manhole products are a core competency of the Afinitas team. We have been trusted for decades to engineer forms for a wide variety of manhole products, including:

- Eccentric Cone Forms
- Concentric Cone Forms
- Slab Top, Transition Slab, Base Slab Forms
- Extended and Straight Base Forms
- Riser Forms
- Drop Base and Drop Riser Forms
- Single Pour Grade Ring Forms
- Battery Grade Ring Forms
- Manhole Joint Rings



Manhole Cone Form



Manhole Base Form



Manhole Riser Form



Afinitas is your source
for Wetcast Forming Systems.

Contact our team at
+1 641-394-4111
or email rfq@afinitas.com

Two-Piece Form

Overall, a straight base two-piece form is a versatile and safe way to create precast concrete base manholes with simple shapes and features like those used for sidewalks, driveways, storm drains and utility access. The form is easy to handle and we produce them with the precise dimensions and exact features required for your specific project. Two-piece forms are ideal when using hole former blockouts for inlet/outlet drainage holes

The Afnitas Advantage

- Manhole Base Diameters: 24" through 144"
- Two-piece design with toggle clamps, seam bars and alignment pins
- Quick pin, swivel eye roll-over trunnions
- Mechanical collapsing inner core

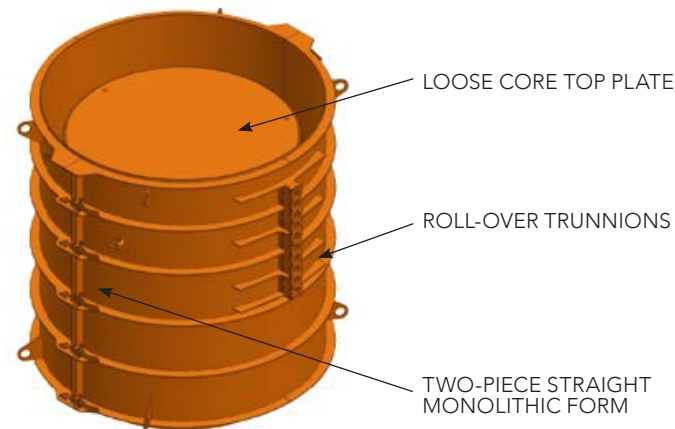

Straight Base Two-Piece Form



Option Full Length Roll Over Trunnions (Straight monolithic manhole base forms only!)



Roll-Over Trunnions

Section View Standard Base

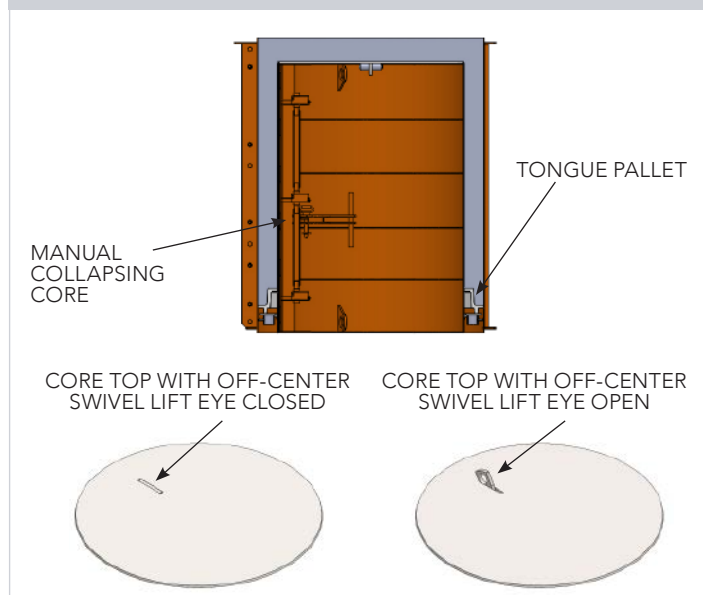

Standard Manhole Base Form

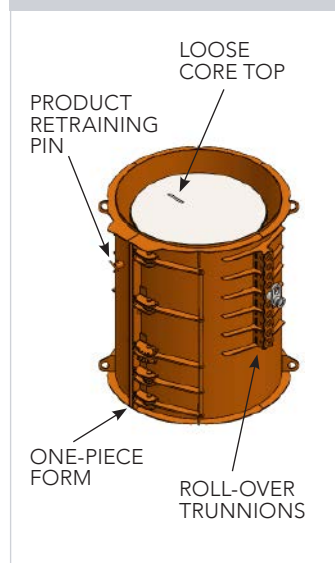

One-Piece Form Option

Two-Piece Form

An extended base two-piece form is used for larger, more complex projects to provide more support and stability. They are ideal for producing products that need to support heavy loads like highway and bridge structures and underground utilities. One-piece forms are perfect when coring holes for inlet/outlet drainage holes

The Afinitas Advantage

- Manhole Cone Diameters: 24" through 144"
- Two-piece design with toggle clamps, seam bars and alignment pins
- Quick Pin, Swivel Eye Roll-Over
- Mechanical collapsing inner core



Above and below: Extended Base Two-Piece Forms



One-Piece Form Option

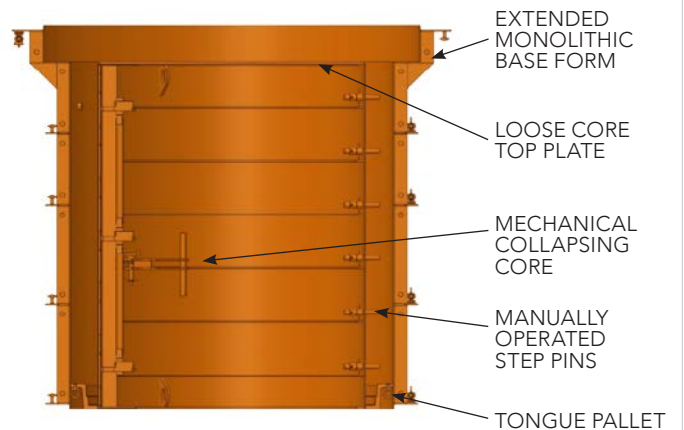

Straight Base & Extended Base Available either in One- or Two- Piece Forms

Why Choose the Quick Strip Option?

By manually moving the "Quick Strip" levers from right to left, found at the bottom of the sub-base, the inner core is collapsed, and the step pins (if step pins are required) are retracted.

Looking for a way to automate
manhole base production?

PRIMA BASE

Learn more about Prima Base – our
automated monolithic manhole base
production system at afinitas.com/prima

QUICK STRIP COMBINATION STRAIGHT MONOLITHIC BASE/
RISER FORM EQUIPMENT INCLUDES MANUAL - OPERATED
STEP PIN RACK ASSEMBLY

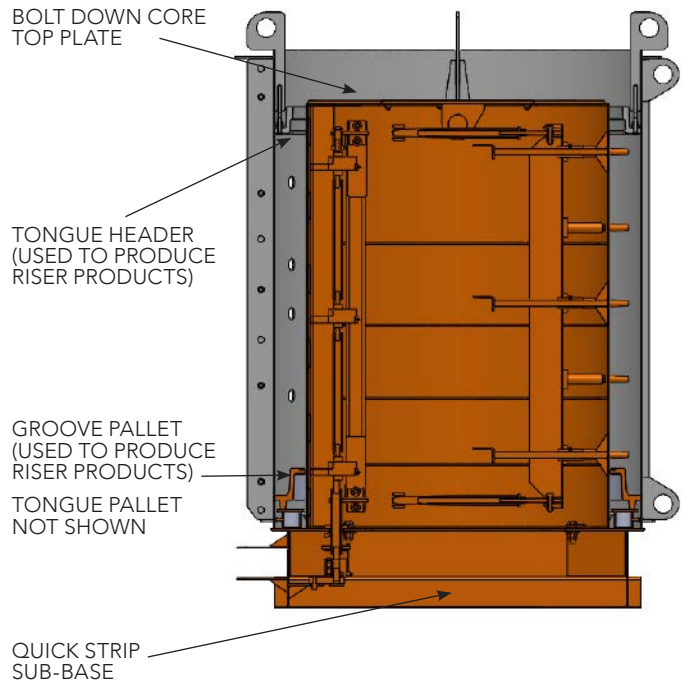

QUICK STRIP EXTENDED MONOLITHIC BASE FORM
EQUIPMENT INCLUDES MANUAL-OPERATED STEP
PIN RACK ASSEMBLY

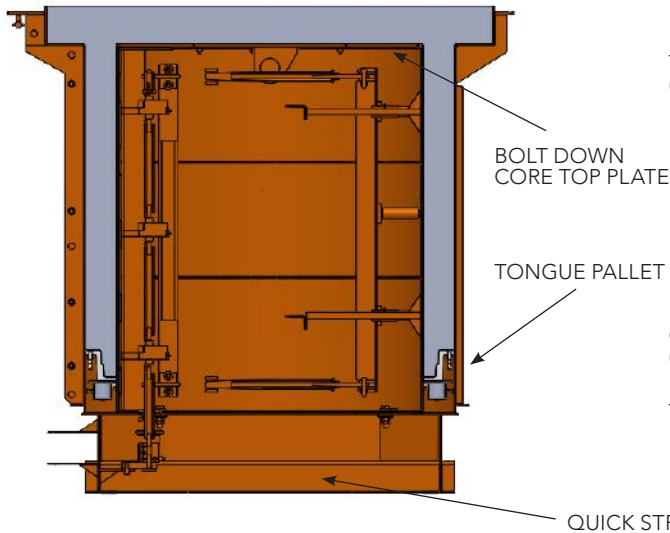

QUICK STRIP COMBINATION EXTENDED MONOLITHIC
BASE/RISER FORM EQUIPMENT INCLUDES MANUAL-
OPERATED STEP PIN RACK ASSEMBLY

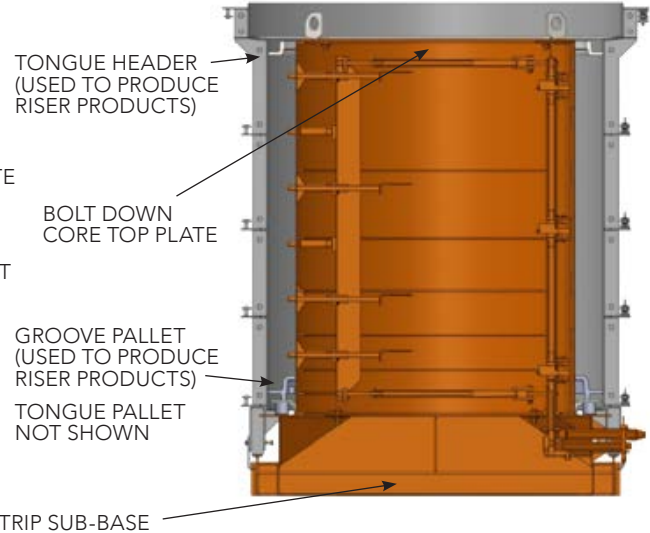

More Quick Strip Options



Quick Strip Straight Base – available in One- or Two-Piece Forms. Standard Fork Truck Pockets “Underneath” the Quick Strip Sub-Base



Option: Fork Truck Pockets “Inside” the Quick Strip Sub-Base



Quick Strip Extended Base - available in One- or Two-Piece Forms



Ganged Form Latch Assembly for Two-Piece Forms and Roll Back Form Doors. Saves time opening and closing vs individual form toggle clamps, especially for taller forms where a ladder may be needed.

Manual Lift Hole Blockout Pins or Lift Insert Assemblies (several makes/models to choose from)



Filler ring to produce straight monolithic base products using an extended base form



Afinitas Has the Options You Need

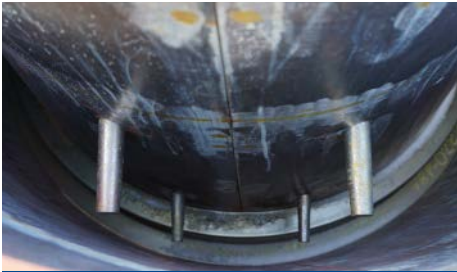

Manual Step Pin Assemblies or Cast-In Plastic Break-Off Step Inserts (several makes/models to choose from)



Option: Core Top Plate with Access Panel (Quick Strip)



Option: Fork Truck Pockets "Inside" the Quick Strip Sub-Base

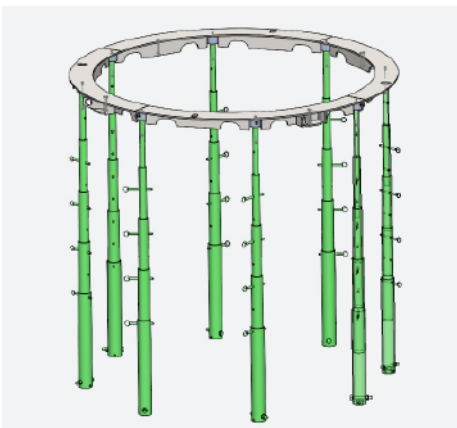

Option: Adjustable Pallet Stool with Leg Kit. NOTICE! Leg kit must be welded to the form sub-base.

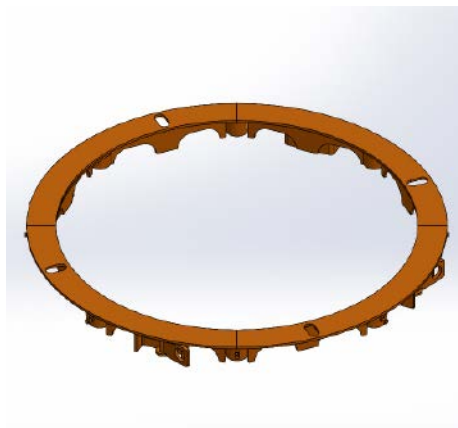

Adjustable Pallet Support Stool with optional Swivel Lifting Eyes shown (standard stool comes with 2½" diameter receiver pipe for customers 2" sch. 40 pipe legs)



Adjustable Flat Pallet Support Stool (standard stool comes with 2½" diameter receiver pipe for customers 2" sch. 40 pipe legs)

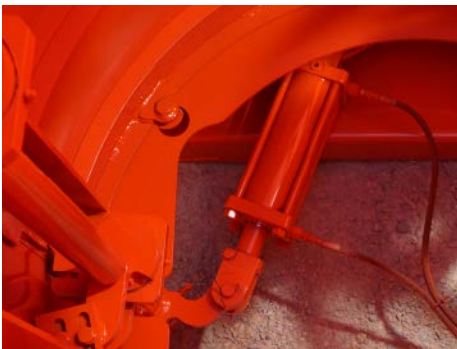

Hydraulic Core Collapsing (inside core view) 24" - 72" Diameter Cores with Quick Strip Sub-Base



Hydraulic Core (outside view showing hydraulic connections)



Quick Strip Sub-Base Top Lever Controls Manual Step Pin Movement Plus Bottom Lever Controls Manual Core Collapse

Hydraulic Step Pins available for 48" - 60" - 72" Diameter Cores with Quick Strip Sub-Base

Available Bolt Down Shovel Plate (offered on Hydraulic Core Collapsing/Hydraulic Steps)

Manhole Base

Quick Strip-Roll Back Options

Why Choose the Quick Strip – Roll Back Options?

With Quick Strip, there is no need to handle the inner core or the optional bolt down core top. Instead, the inner core and step pins (if required) are collapsed and retracted by simply moving the Quick Strip levers from right to left at the bottom of the sub-base. This simple, easy, and safe process reduces crane picks saving time and money on the job site.

With the Roll Back form the doors are manually rolled open/close. The manufacturing team does not have to handle the outer form with an overhead hoist. This makes the process simpler and safer.



Option: Safety Catwalks Available on One Side or Two Sides



Quick Strip Sub-Base Top Lever Controls Manual Step Pin Movement plus Bottom Lever Controls Manual Core Collapse

Additional Features

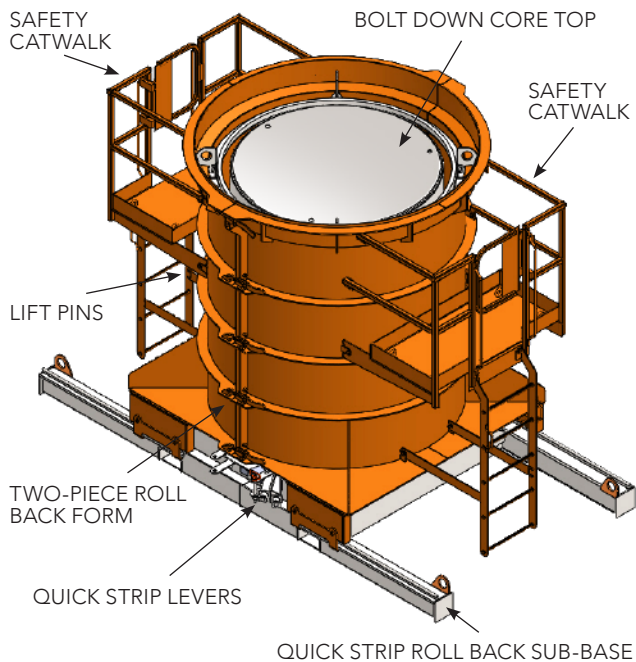

We offer Large Format 84" diameter-plus forming as well as Sub-Base Strip

Available on either One- or Two-Piece Forms

Benefits of Sub-Base Strips

With this option, you can manually collapse the inner core from the underside of the sub-base, without having to handle or rotate the inner core or core top. (Core top is bolted to the top of the core).

- Reduce crane picks saving time and money.
- Simpler and easier: move the Quick Strip lever found at the bottom from right to left to manually collapse the core and the step pins (if required) are manually retracted.
- Safer: The Sub-Base Strip option is safer than traditional methods of form removal. There is no need to handle heavy objects, and there is less risk of accidents.



Riser – One-Piece (above) with Sub-Base Strip (below) and Optional Fork Truck Tubes



Straight Base and Extended Base

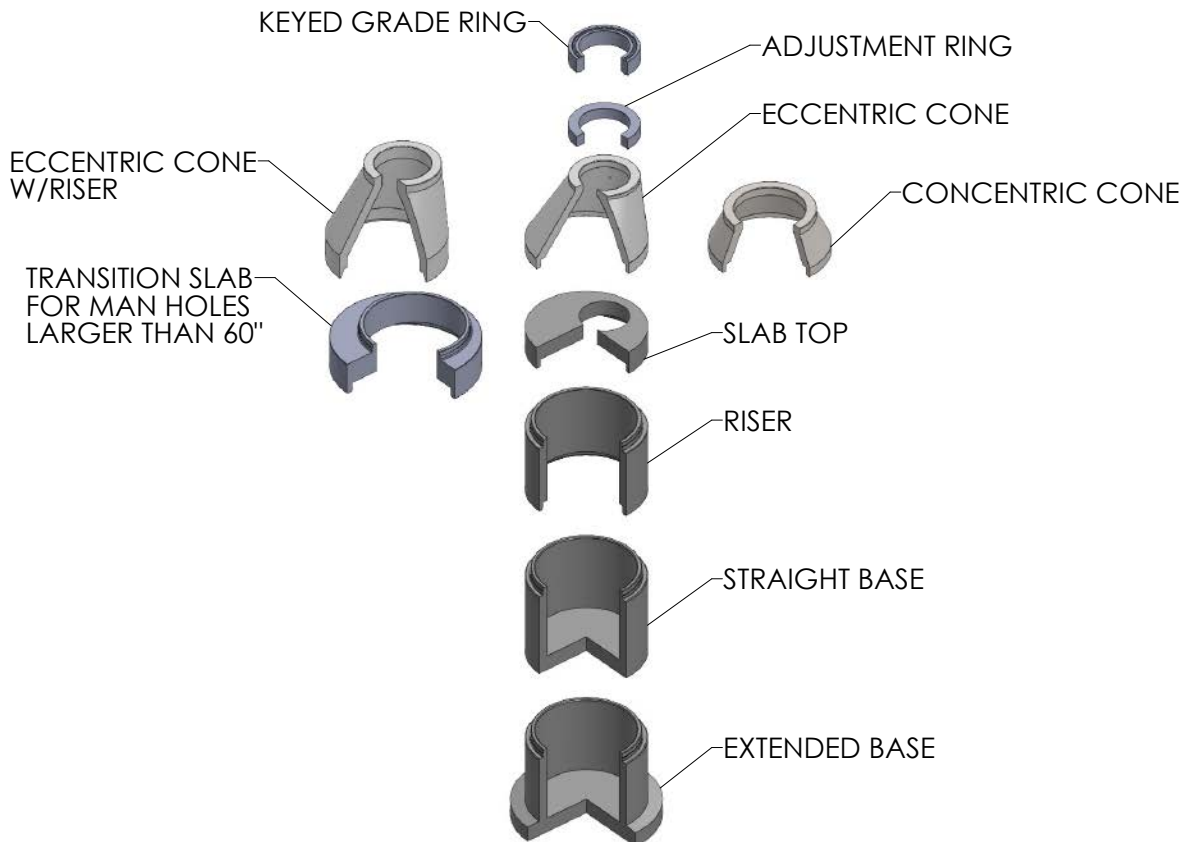
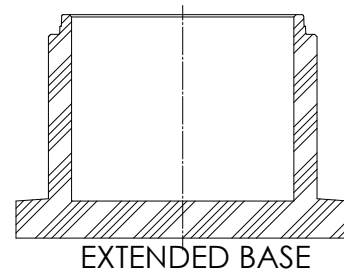
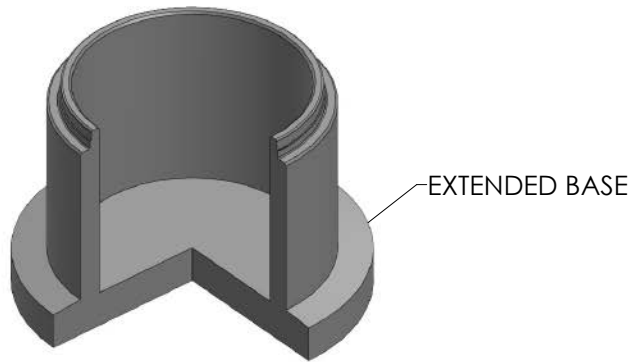
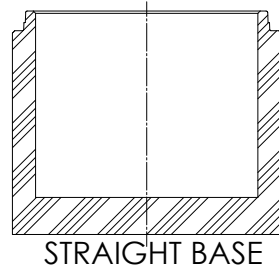
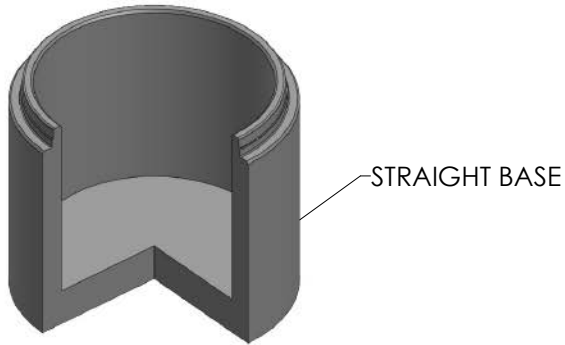

Afinitas brings you the industry's best formwork and a whole lot more.

Afinitas is the premier platform of precast concrete infrastructure equipment and services.

With decades of experience in the pipe and precast concrete markets, we provide manufacturers around the world with the gold standard in precast concrete product production equipment, highly engineered drycast and wetcast forms and a wide variety of concrete accessories.

Our combined strengths mean more concrete machinery engineering resources, manufacturing know-how and pipe and precast concrete industry experience is ready to help you create the ideal production systems for your infrastructural concrete product needs.



SmartRoll™ Form Controller - Intelligent Safety Brake reduces form swinging up to 90%.



Lifting Anchors, Fixation Inserts and other precast accessories



Cone Cages from Haala Industries brand





Manhole Base Forming Systems

Equipment & Automation



Concrete Accessories

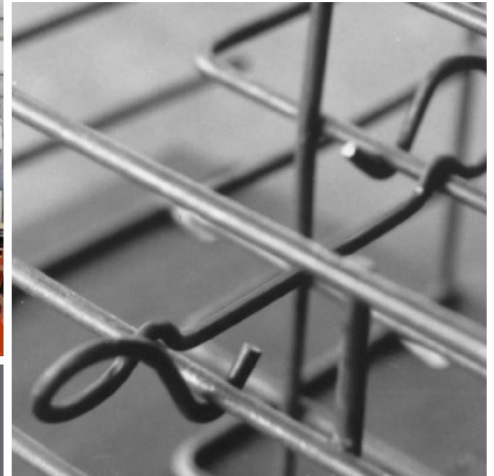

Forming Systems

Intelligent Infrastructure Solutions
Visit www.afinitas.com to learn more.

Afinitas Forming Systems Division

Iowa

928 W Milwaukee
New Hampton, IA 50659
Phone: 641-394-4111
Fax: 641-394-4542
rfq@afinitas.com

Ohio

1701 Moler Road
Columbus, OH 43207
Phone: 614-444-2184
rfq@afinitas.com



Intelligent Infrastructure Solutions

Afinitas is a global, comprehensive and customer-oriented equipment, automation, forming and accessories platform for precast concrete and infrastructural products.

Afinitas Forming Systems Division:

928 W. Milwaukee | New Hampton, IA 50659 USA | +1 641-394-4111 | rfq@afinitas.com | www.afinitas.com