



# Flared End Forming Systems



## Quality Formwork for Every Application

### Traditional Pour Flared End Forms

- Wetcast Flared End
- Traditional Horizontal Pour
- NextGen Vertical Pour

## Heavy steel construction designed for strength, durability and performance

Afinitas is known for bringing together the top engineering and manufacturing expertise in the industry to build best-in-class precast forming systems. Our wide range of quality products are backed by knowledgeable and responsive customer sales and manufacturing team members who are there to assist you throughout the life of your form. And to that point, our forms are built to last. We combine heavy-duty steel with an innovative approach to manufacturing that will ensure we can help you take your business where you want to grow.

Wetcast formwork is a core competency of the Afinitas team. We have been trusted for decades to engineer forms for a wide variety of applications, including:

- Manhole Cone Forms
- Manhole Riser Forms
- Manhole Slap Top, Transition Slab, Base Slab Forms
- Box Forms
- Flared End Forms
- Battery Grade Ring Forms
- Manhole Joint Rings



Manhole Cone Form



Box Form



Flared End Form



**Afinitas is your source**  
for Wetcast Forming Systems.

Contact our team at  
**+1 641-394-4111**  
or email [rfq@afinitas.com](mailto:rfq@afinitas.com)

## Traditional Horizontal Pour Flared End Form

Designed specifically for the traditional horizontal wetcast method of manufacturing flared end sections, this innovative system offers a perfect solution for creating high-quality flared ends with exceptional efficiency. Our precise design ensures consistent flared end structures resulting in an exact fit during pipe assembly.

### The Afnitas Advantage

- Heavy steel construction, designed for strength, durability and performance
- Diameters 12" through 96"
- Solid tapered form design with toggle clamps and alignment pins
- Solid tapered inner core
- Form includes two product retaining pins to retain the product when jack stripping the core



Traditional Pour Flared End Forming

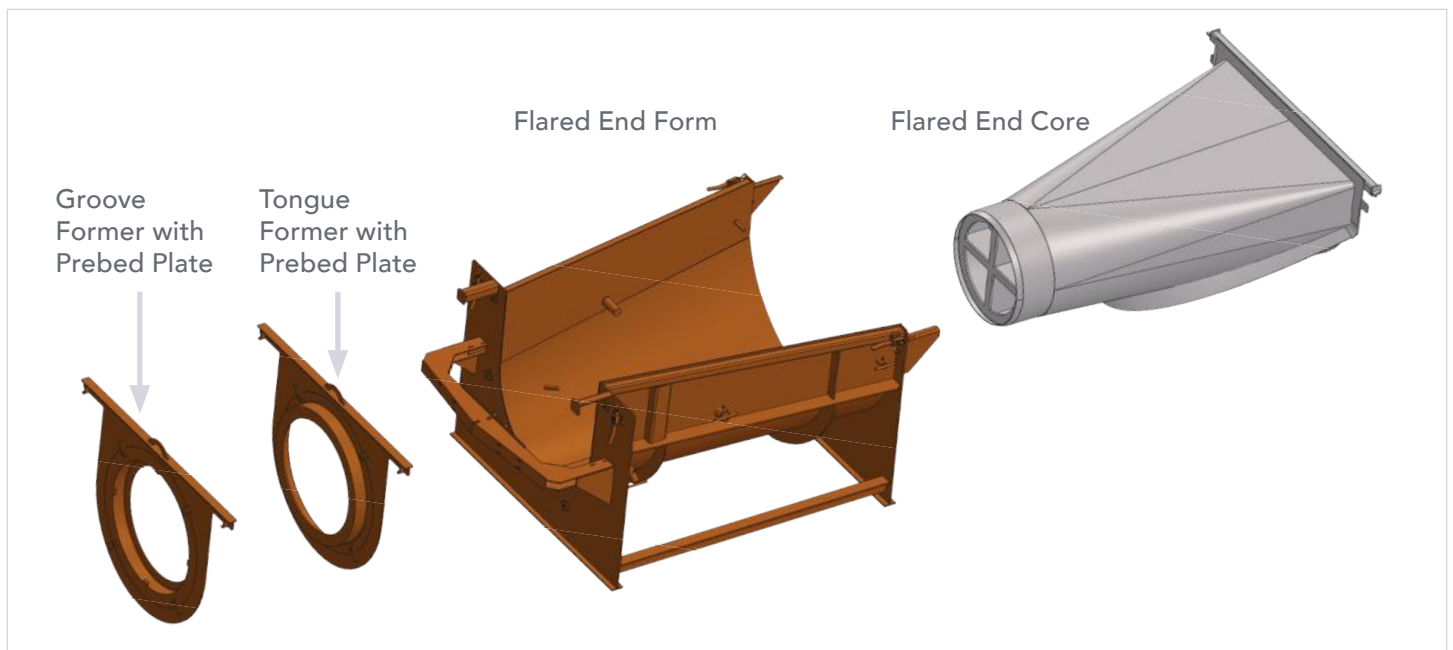

## Traditional Horizontal Pour

### Flared End Form Diagrams

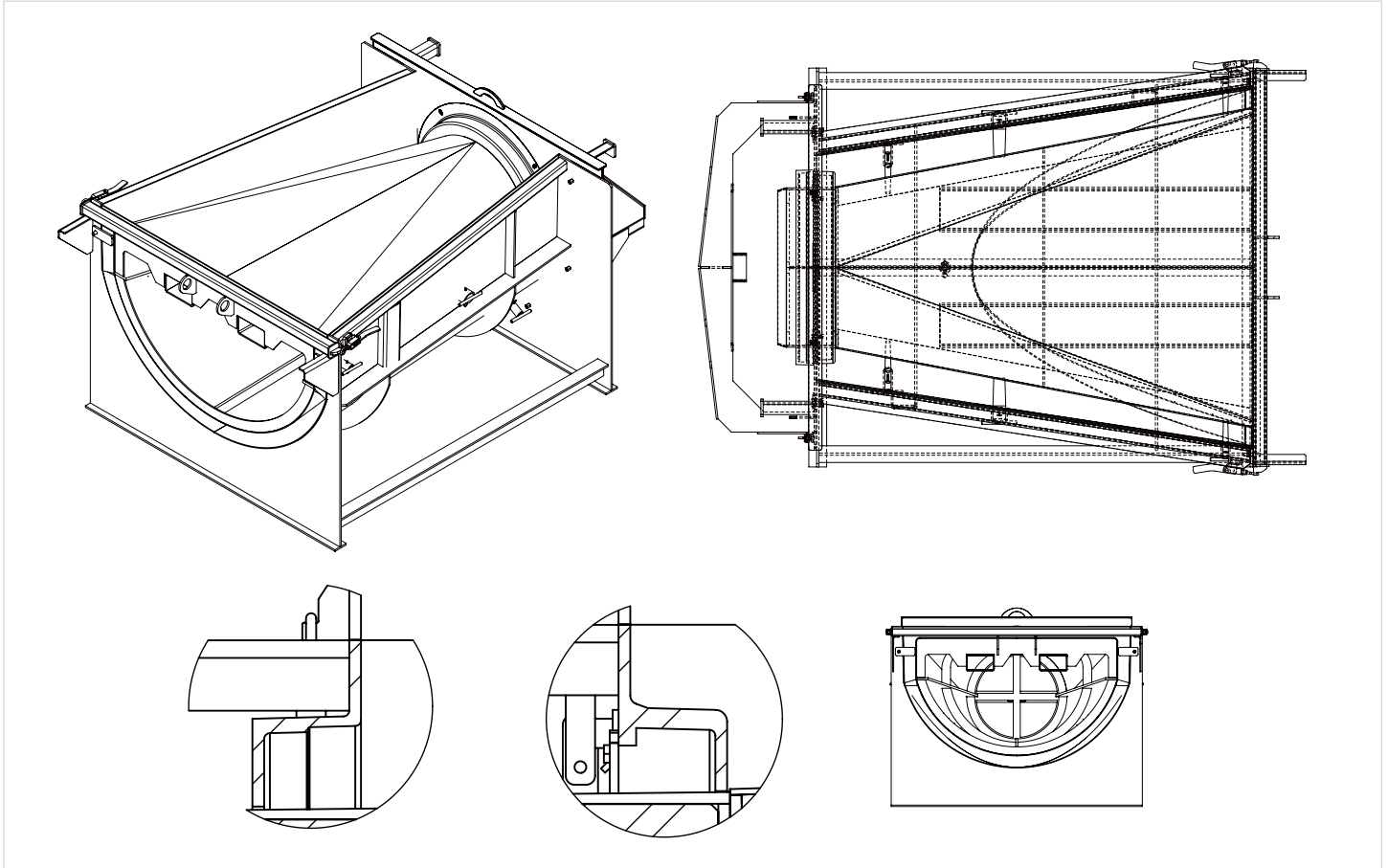

### Form Options



Steel Block Outs Retainer Pins, Hole Formers, Lift Pins or Grate Pin Block Out Assemblies designed to your needs



Vibrator Mounting Brackets (various makes/models to choose from) Air or Electric Vibrators are also available



One Side or Two Sides, Catwalk(s) with Safety Door(s) and Ladders with "Slipknot" Rungs



20-Ton Bottle Jack

# NextGen Vertical Pour\*

## Flared End Form

Our NextGen forming systems have the same durability as our traditional forms but are more compact. In addition, they offer the ability to do vertical pouring which maximizes factory floor space.

## The AFINITAS Advantage

- Casting the NextGen flared end forming in the vertical position, allows for quick, easy set-up and strip out, keeping the operator in mind for safe handling.
- NextGen flared end forming can easily be set-up and stripped out using an overhead crane vs. the traditional, upside-down pour, flared end forming. (The traditional flared end forming requires multiple picks using a fork truck, and sand pile or rubber tires to turn the product in an upright position)

With NextGen flared end forming you'll have:

- Less concrete finishing
- Easier, safer work surface clean up
- Compact, all-in-one forming unit vs traditional, multi-piece components to handle.
- Heavy steel construction designed for strength, durability and performance
- Diameters 12" through 96"
- NextGen roll-back form doors with toggle clamps and alignment pins
- Solid tapered inner core
- Hydraulic jack strip assist sub-base with fork truck pockets
- Throat apron blockout, loosely bolted to the sub-base

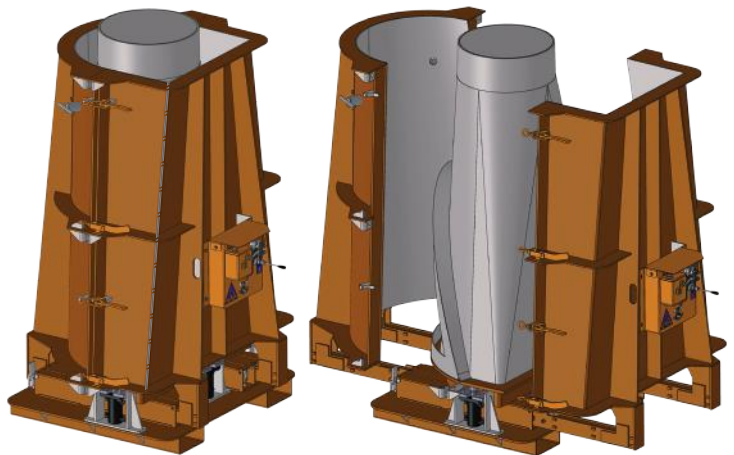

SmartConnect™



Hydraulic Jack Strip Assist

\* Patent-pending.

## NextGen Vertical Pour

### Form/Product Strip Out with Overhead Crane Process



1. Removal of either the tongue former or groove former. The added safety catwalk assists the operator with this task.



2. Opening the roll-back form doors.



3. Using the added SmartConnect™ to engage the hydraulic strip assist cylinders; break the bond of the concrete to the inner core.



4. Continue to overhead strip the product, leaving behind the complete form system.

## Product Tip Down with Overhead Crane Process

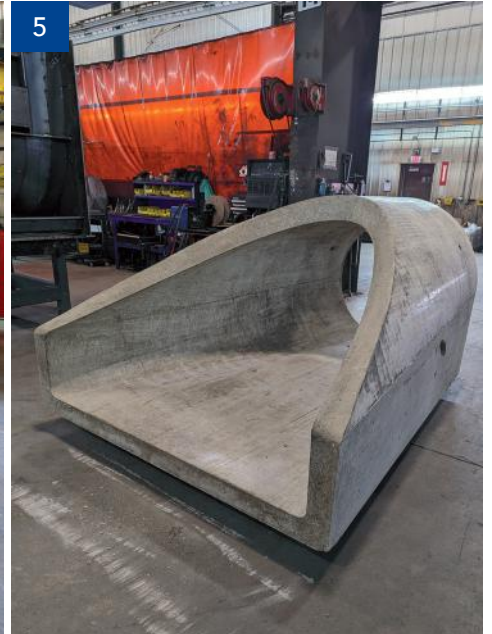
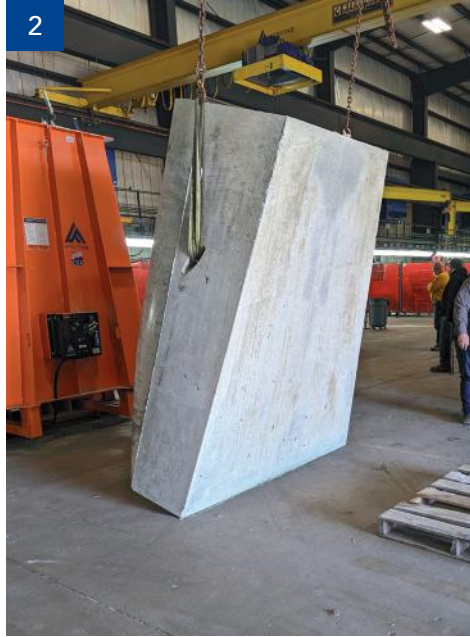

**Need concrete accessories?**

See our selection at [afinitas.com/accessories](https://afinitas.com/accessories).

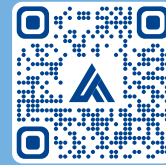

# “NextGen” Vertical Pour vs. “Traditional” Horizontal Pour Flared End Forming

## Comparison Chart

### “Traditional” Horizontal Pour Flared End forming

### “NextGen” Vertical Pour Flared End Forming

#### Set-Up to Pour Procedure

1. Clean and oil form.
2. Clean and oil core.
3. Place cage onto core.
4. Clean and oil joint former.
5. Clamp joint former to form.
6. With fork truck, pick core up and place cage onto core.
7. Place core/cage into form.
8. Clamp core to form.
9. Place form product retaining pins into position.

1. Form doors in the open position, clean and oil the form, core and apron pallet.
2. Using an overhead hoist, place cage around the core.
3. Clean and oil the joint former to be used.
4. Close the form doors and clamp the form seams.
5. Using an overhead hoist, place the joint former on top of the form or core, (either groove or tongue).

**Note:** Customer may opt to fill the form with concrete, filling close to the top of the form and then introduce the joint former.

#### Strip Out Procedure

1. Un-clamp the core toggle clamps.
2. Using a 20-ton bottle jack, place the jack on the form push bracket to push against the core solid end, jack the core outward to “break the concrete to core bond”.
3. Using a fork truck, remove the inner core only.
4. Remove the form product retaining pins from the product.
5. Un-clamp and remove the joint former from the product.
6. Using a fork truck, remove the product from the form, lifting straight up.
7. Product is produced up-side down. Roll the product over either in a sand pile or on rubber tires.

**Notes:** Care is needed to roll the product over, so NOT to break or spall the product). All steps above require using a fork truck.

1. Remove the joint former from the product.
2. Un-clamp the form toggle clamps, and pry flat side door against product pin or door locks. Roll the “flat” form door open. Remove product pins or un-lock door locks and roll the “round” form door open.  
**Step 2 Note:** NextGen Flare will come with product pins **OR** door locks.
3. Using the customer supplied cordless drill, connect to the SmartConnect system to jack strip the flared end apron pallet and product upward, to “break the concrete to core bond”.
4. Using an overhead crane and proper lifting device, connect to the cast-in product lift inserts, removing the product from the core, lifting straight up.
5. Lay the product down in the up-right position.



### Introducing SmartJax™\*

## A revolutionary way to firmly stool up pallets inside concrete forms

Our **patent-pending SmartJax™** adjustable support stand offers many advantages over existing pallet support systems:

**Simply Genius!** You will love the speed and convenience of having a single unit to support and secure your pallet. Stand and magnets all-in-one.

**Safe** – say goodbye to the splintering and unreliability of using wood pieces, PVC or hollow core concrete traditionally used as supports.

**Strong** – our stand is built to last as a heavy steel fabricated weldment.

**Speedy** – multiple hole locations in the support tube make pin-facilitated height adjustment quick and easy.

### Product Highlights

- 8000 pound capacity\*\*
- 12" overall height with adjustment up to 18" tall in 1" increments, making it simple to size to your requirements
- 1000 pound on/off button base magnet for attachment to form sub-base
- Interchangeable leg tube heights



SmartJax™ can be used on both box and round forms.



Adjusts to a wide variety of heights.

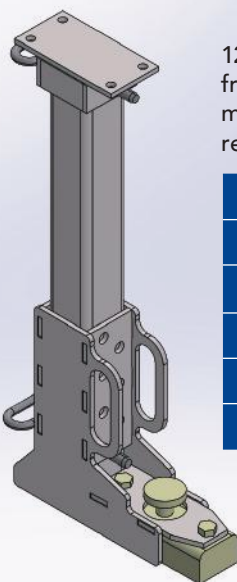

12" overall height with adjustment from 12" to 23" in 1" increments, making it simple to size to your requirements.

SJL 2	24" – 35"
SJL 3	36" – 47"
SJL 4	48" – 59"
SJL 5	60" – 71"
SJL 6	72" – 83"
SJL 7	84" – 95"

\* Patent-pending

\*\* Depending on pallet design, a minimum of 3 to 4 SmartJax™ (or more) are to be used at all times to support a flat pallet, pallet support stool, joint forming pallet or any combination along with the concrete load.

# SmartConnect™ Cordless Hydraulic Power System for Collapsible Cores

Precast concrete forms with collapsible cores make it easier to remove the product from the form. However, powering up the hydraulics to retract and expand the core can be a hassle. Typically a large cart carrying a power unit, power cords and hoses must be wheeled to the form. The hoses must be attached to the hydraulics on the form, the unit must be plugged in and once the core moves, everything must be disconnected before the cart can move to the next form. This process not only takes time but it wastes time that could be spent working on multiple forms at once.

## Introducing SmartConnect™ \*

An Intelligent Bolt-On Power Unit for hydraulic collapsible cores. With SmartConnect™, you have a self-contained hydraulic power unit that is mounted directly on the form. There are no electric carts or cords. The unit is powered by a standard 20 volt - 1/2" drive cordless drill that uses the same hydraulics to operate the core to open and close.

## Benefits of SmartConnect™

- **Save time — at least 10 mins. or more per form!**
  - No wheeling of carts around the plant
  - No hoses and cords to connect and disconnect
  - No more waiting — all you need is a cordless drill to operate the unit, allowing you to work on many forms at once
  - Ultimately, your strip-out and set-up will go faster
- **Increased Safety**
  - With no electrical cords strung throughout the plant, tripping hazards are reduced
  - Minimizes potential electrical shock hazards if water is present
- **Space Saver**
  - Eliminating the bulky cart means more open floor space in an already equipment-packed area
- **Flexible**
  - Works on AFINITAS forms up to 7' x 7' boxes and manhole form diameters up to 72"
  - Retrofit your existing forms or add to new AFINITAS form purchases
- **Quick Payback**
  - SmartConnect costs significantly less than a 110V hydraulic cart system
  - When you calculate the productivity gains and reduced safety risks, the system pays for itself in no time (in most cases 3 years or less).

\* patent-pending technology



SmartConnect™ is mounted directly on the form to power the collapsible core hydraulics.



The self-contained unit is not dependent on any other equipment except a standard 20 volt - 1/2" drive cordless drill

Watch the SmartConnect™  
Cordless Hydraulic Power  
System Video



## Afinitas brings you the industry's best formwork and a whole lot more.

Afinitas is the premier platform of precast concrete infrastructure equipment and services.

With decades of experience in the pipe and precast concrete markets, we provide manufacturers around the world with the gold standard in precast concrete product production equipment, highly engineered drycast and wetcast forms and a wide variety of concrete accessories.

Our combined strengths mean more concrete machinery engineering resources, manufacturing know-how and pipe and precast concrete industry experience is ready to help you create the ideal production systems for your infrastructural concrete product needs.



Cone Cages from Haala Industries brand



### SmartSet™ Curing Systems

- Next-gen and basic direct-fired steam generators
- Controls and airflow systems
- Misting and drying components
- Kilns, piping, moving floors
- Dedicated tech team and service

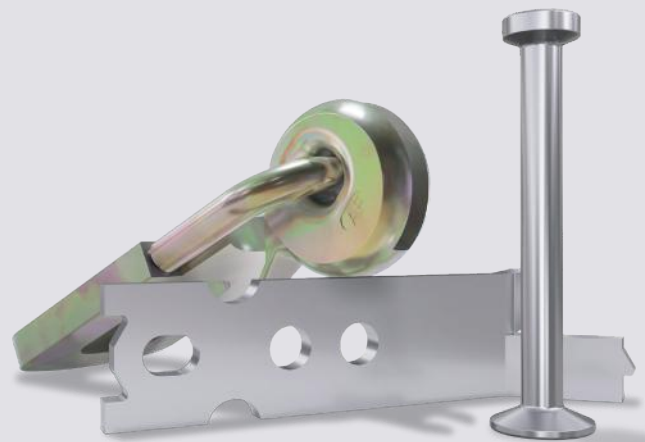

Lifting Anchors, Fixation Inserts and other precast accessories



# Flared End Forming Systems

Equipment & Automation



Concrete Accessories

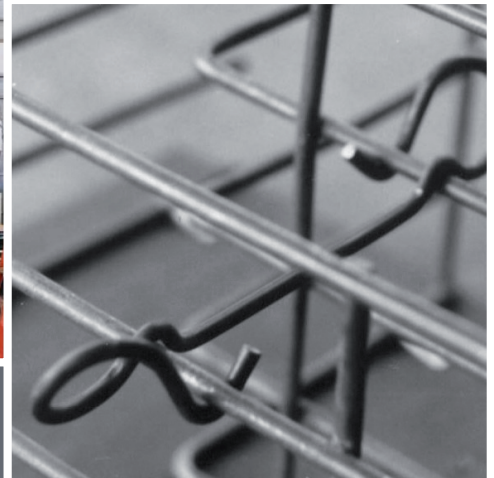

Forming Systems

Intelligent Infrastructure Solutions  
Visit [www.afinitas.com](http://www.afinitas.com) to learn more.

## Afinitas Forming Systems Division

### Iowa

928 W Milwaukee  
New Hampton, IA 50659

Phone: 641-394-4111

Fax: 641-394-4542

[rfq@afinitas.com](mailto:rfq@afinitas.com)

### Ohio

1701 Moler Road  
Columbus, OH 43207

Phone: 614-444-2184

[rfq@afinitas.com](mailto:rfq@afinitas.com)



### Intelligent Infrastructure Solutions

Afinitas is a global, comprehensive and customer-oriented equipment, automation, forming and accessories platform for precast concrete and infrastructural products.

Afinitas Forming Systems Division:

928 W. Milwaukee | New Hampton, IA 50659 USA | +1 641-394-4111 | [rfq@afinitas.com](mailto:rfq@afinitas.com) | [www.afinitas.com](http://www.afinitas.com)