



Handhold Bolt On

SH??? - Stainless Steel SH??? - Aluminium

CASWICK

Part of the Afinitas Family



The bolt on handhold aids access to and from manholes and chambers. Once the manhole cover is removed the handhold is raised and secured with a twisting action so that it protrudes through the access. This gives the user additional security whilst transitioning from surface level into the chamber. The bright cap creates a visual marker to indicate to others that the manhole is open. Once the user has used the handhold to aid their exit, the handhold is released and lowered with a twist action. The entire handhold remains below the level of the cover until access is needed again.

The handhold is offered manufactured from either light weight aluminium with plastic end caps or an all stainless steel version for more demanding environments.

To raise the handhold grip the top of the pole and pull vertically upwards. As the handhold nears the top you will feel the locating pin hit the underside of the bracket. Whilst applying slight upward pressure rotate the pole until the pin can be felt to drop into a slot. Continue to lift the pole until the pin emerges through the top of the slot. Rotate the pole until the pin can be felt to drop into a second slot. This locks the handhold in the raised position.

Check the handhold is secure before use.

To lower the handhold pull the pole upwards whilst rotating.

The pin will be felt to drop through a slot and the handhold will be able to be lowered. Do not drop the pole.

Ensure the handhold is rigidly fixed before entering manhole.

Materials:

Aluminium version;

Pole: Grade 6082 Aluminium

Brackets: Grade 5083 Aluminium

Location pin: Acetal

Bolts: BZP

Materials:

Stainless steel version;

Pole: Grade ??? Stainless steel

Brackets: Grade ??? Stainless steel

Location pin: ??? Stainless steel

Bolts: ??? Stainless steel

Loading

The handhold meets the following criteria:

Axial Loading

The pole maintains an axial load of 2.0kN for 60 seconds without failure

Load Deflection

A 115kg person exerts a 220N force horizontally on the handhold when leaning back. The graph below shows a typical load deflection cycle for the handhold. The bracket withstands 1000N without failure.

Fixing

The chosen fixing must be suitable for the surface which the handhold is to be fixed too and withstand a minimum pullout of 8.5kN and a minimum shear of 2.0kN.

Load Deflection

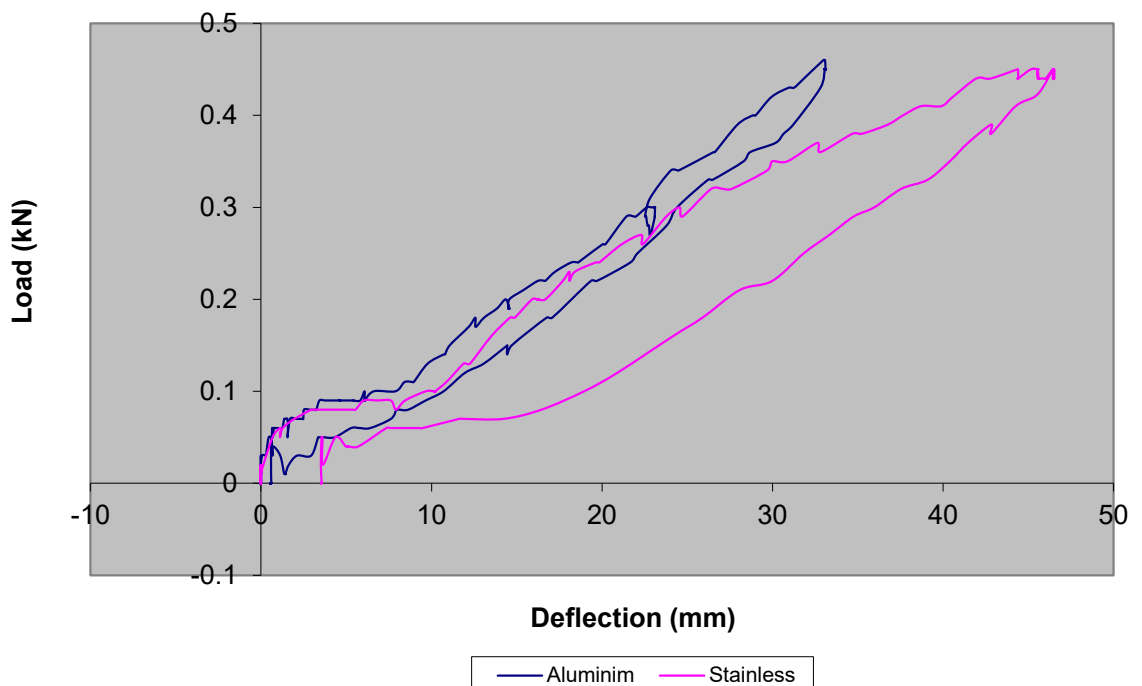

1.

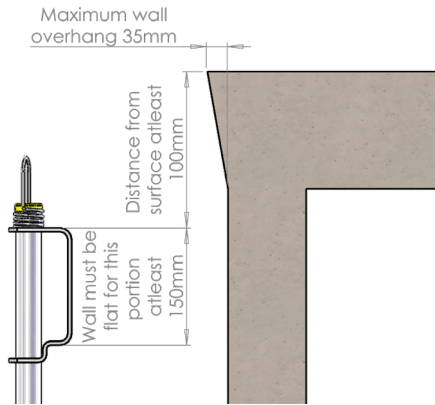

Ensure wall is of sufficient strength for chosen fixing method and is vertically flat for atleast 150mm at the drilling position

2.

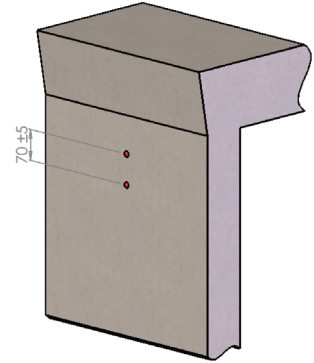

Mark and drill two holes to suit chosen fixing using bracket as a template. (See technical requirements)

3.

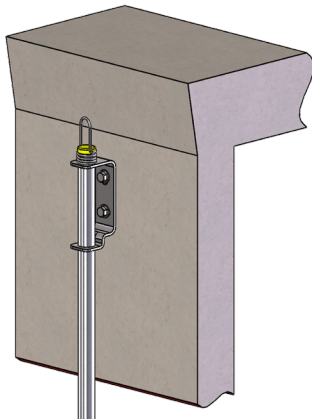

Loosely secure bracket with both fixings

4.

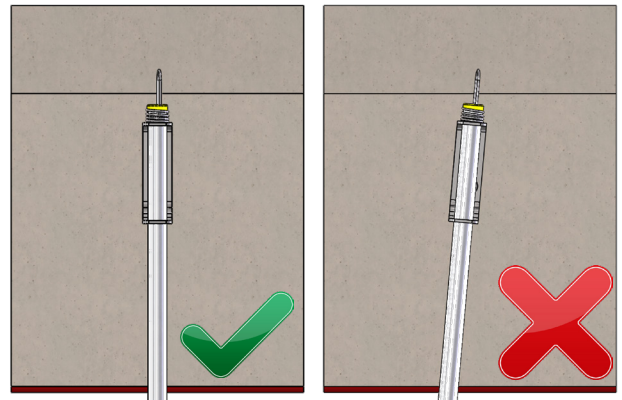

Ensure bracket is vertical

5.

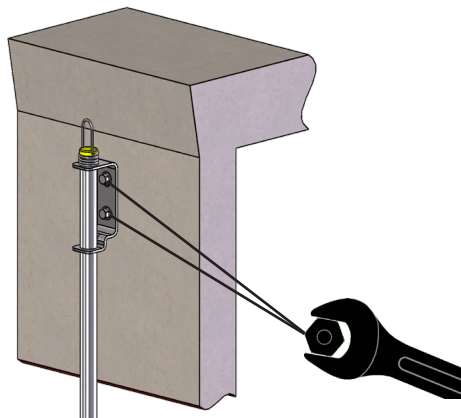

Tighten fixings to their recommended torque

6.

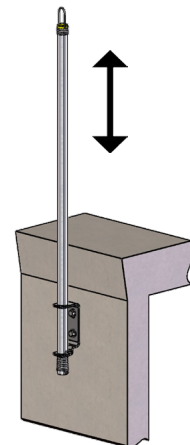

Ensure handhold can be raised and lowered safely from the usual working areas

Raising the handhold

1.



To raise the handhold lift the pole gently upwards.

2.



The pin will be felt to strike the bottom of the bracket.

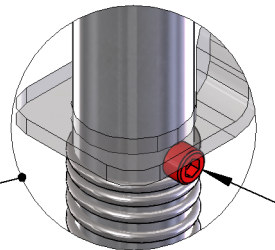

3.

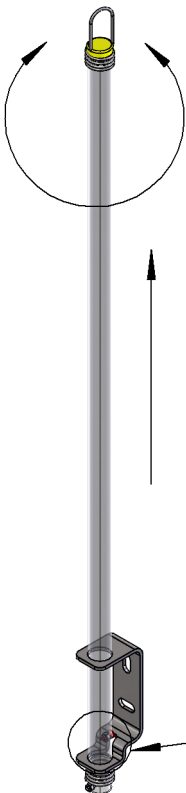

Rotate the pole whilst applying gentle upwards pressure. The pin will drop into the slot at the rear of the bracket. Continue to apply upwards pressure until the pin emerges from the top of the slot in the bracket.

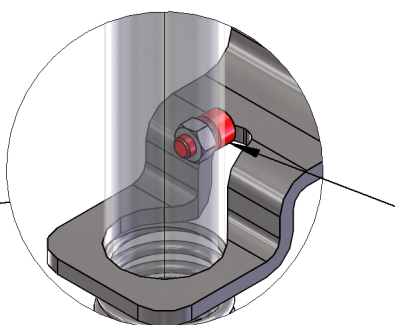

4.

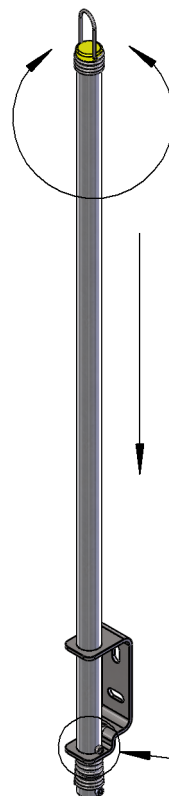

Rotate the pole until the pole is felt to drop. Ensure that the pin is in the positions shown which prevents the pole from dropping. Ensure the pole is secure before use. Reverse this procedure to lower the pole.

