

Description:

The cable hanger creates a bracket which cables can be looped around or hung over in a cast concrete cable box. This can be to tidy installed cables or keep cables out of harms way during termination. The plugs can be hammered into formed holes (drilled or similar) in the concrete or supported in the formwork during casting. The cable hanger plugs are manufactured from high impact grade virgin polypropylene. The rails are manufactured from aluminium tube. The plugs can also be supplied individually to allow your own reinforcement to be fitted, for example galvanised steel. The product options are detailed below;

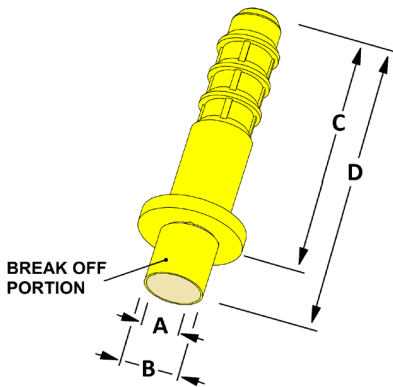
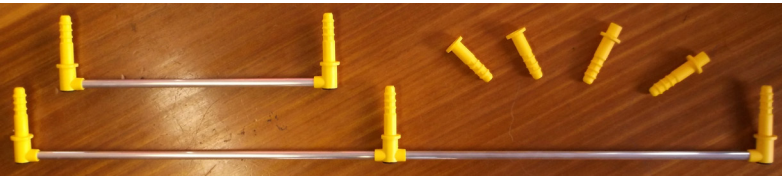

Plug 14mm flange flat break off

The plug has a break off portion on the open end of the insert which is pushed into a 20mm diameter formed hole in the concrete formwork. This supports the plug whilst the concrete is poured. Once the concrete has hardened the formwork is removed, the break off portion snaps away with the formwork leaving the plug in the concrete. The internal diameter is sized to accept 14mm diameter components such as a formed metal bar or the Caswick hammer in cable support system.

Code	A (internal diameter)	B (breakoff diameter)	C (plug casting length)	D (overall length)
SP197	14 mm	20 mm	84 mm	104 mm

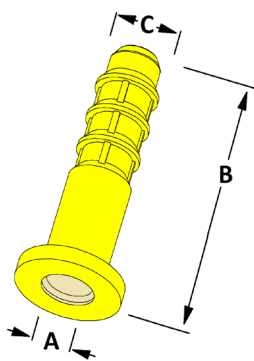

Plug 14mm

The plug is hammered into a formed 19mm diameter hole in the concrete structure or supported by a pin from the inside of the formwork during pouring. This can have been formed by a pin during casting or through drilling. The internal diameter is sized to accept 14mm diameter components such as a formed metal bar or the Caswick hammer in cable support system.

Code	A (internal diameter)	B (plug length)	C (plug diameter)
SP196	14 mm	84 mm	20 mm

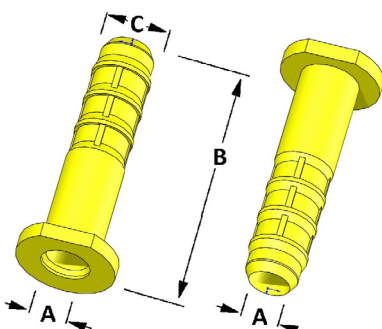

Plug 14mm Open

The plug is supported by a pin on the outside of the concrete formwork whilst the concrete is poured. The internal diameter is sized to accept 14mm diameter components such as a formed metal bar or the Caswick hammer in cable support system.

Code	A (internal diameter)	B (plug length)	C (plug diameter)
SP204	14 mm	84 mm	20 mm

Cable holder - formed holes

The cable holder comprises of two or three plastic plugs which support a length of aluminium tube. The plugs are hammered into two or three holes 19mm diameter formed in the concrete communication chamber wall. The holes can be formed by pins at the time of casting or through drilling once the concrete has hardened. The cables are then tucked behind or hung over the aluminium bar or brackets can be hung from the bar which in turn support the cables.

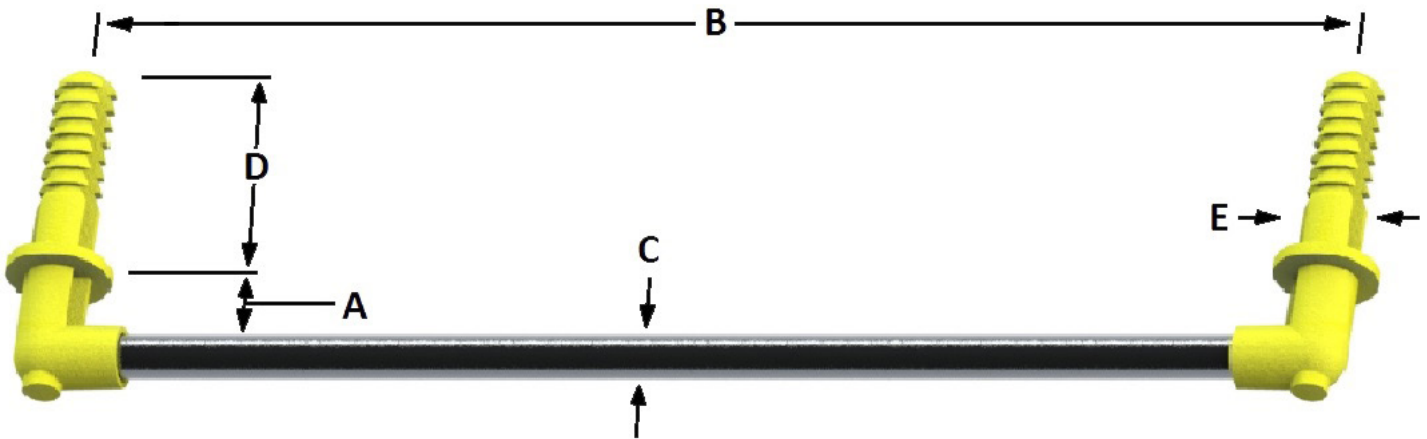

Cable hanger without central support

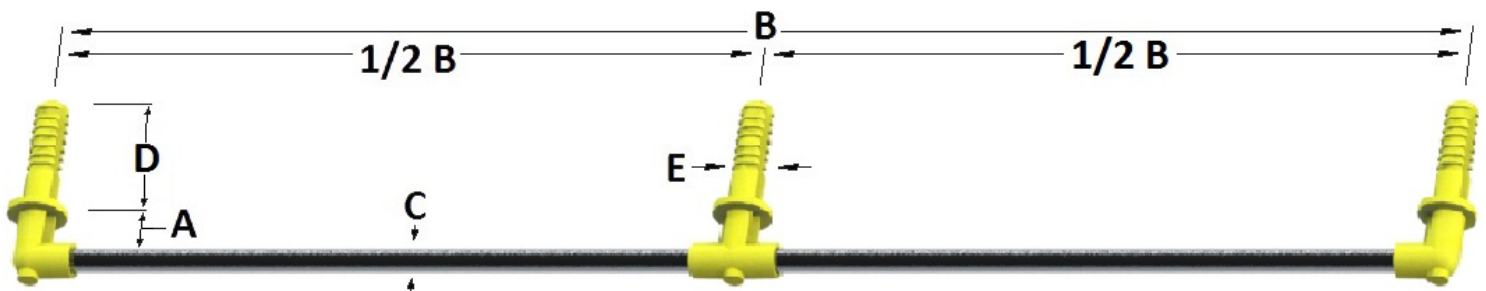

Cable hanger with central support

Caswick Code	Afnor NF P98-050-1 reference	A (space behind bar)	B (hole centres)	C (wire thickness)	D (hole depth)	E (plug diameter)	Central support?
	L1T / L1C	25 mm	430 mm	14 mm	80 mm	20 mm	No
	L2T / L2C	25 mm	1060 mm	14 mm	80 mm	20 mm	No
	L3T / L3C	25 mm	1200 mm	14 mm	80 mm	20 mm	Yes
	L4T	25 mm	790 mm	14 mm	80 mm	20 mm	No
	0.5 L4T	25 mm	1680 mm	14 mm	80 mm	20 mm	Yes
	K1C	25 mm	585 mm	14 mm	80 mm	20 mm	No
	K2C	25 mm	1285 mm	14 mm	80 mm	20 mm	Yes
	K3C	25 mm	2040 mm	14 mm	80 mm	20 mm	Yes

Cable holder - hammer into inserts

The cable holder comprises of two or three plastic plugs which support a length of aluminium tube. The plugs are hammered into corresponding Caswick inserts as shown on page 1 of this brochure once the concrete has hardened. The plastic inserts shown on page 1 are installed at the time of casting the concrete. The cables are then tucked behind or hung over the aluminium bar or brackets can be hung from the bar which in turn support the cables.

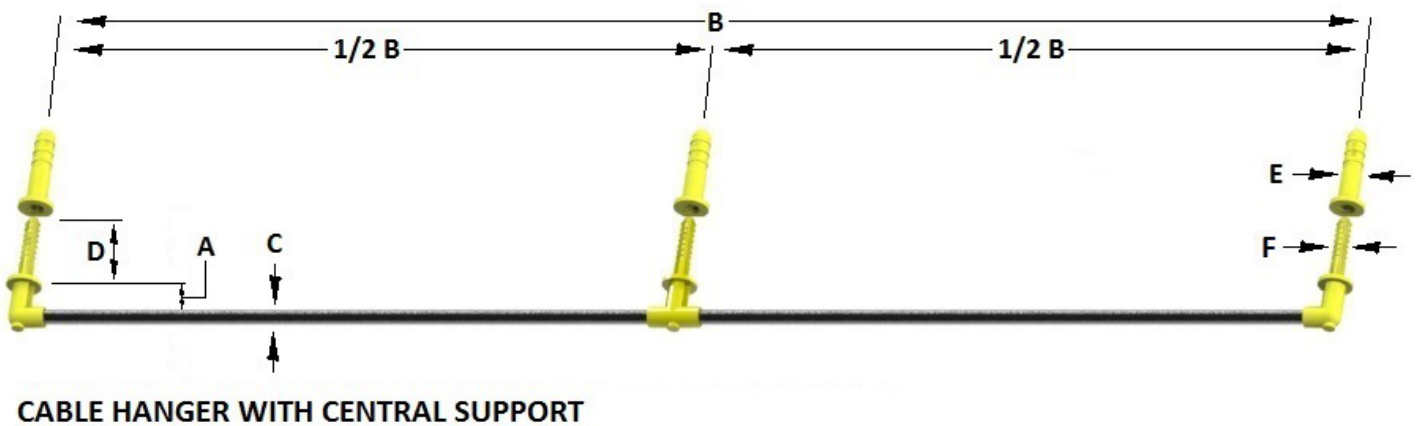
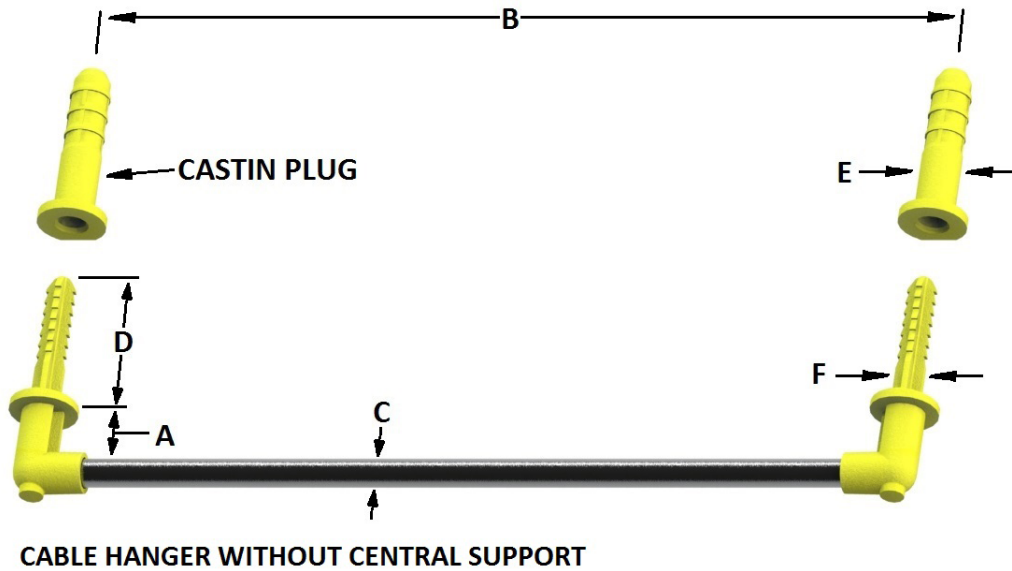

Caswick Code	Afnor NF P98-050-1 reference	A (space behind bar)	B (hole centres)	C (wire thickness)	D (hole depth)	E (plug diameter)	F (Barb diameter)	Central support?
	L1T / L1C	31 mm	430 mm	14 mm	80 mm	20 mm	14.5mm	No
	L2T / L2C	31 mm	1060 mm	14 mm	80 mm	20 mm	14.5mm	No
	L3T / L3C	31 mm	1200 mm	14 mm	80 mm	20 mm	14.5mm	Yes
	L4T	31 mm	790 mm	14 mm	80 mm	20 mm	14.5mm	No
	0.5 L4T	31 mm	1680 mm	14 mm	80 mm	20 mm	14.5mm	Yes
	K1C	31 mm	585 mm	14 mm	80 mm	20 mm	14.5mm	No
	K2C	31 mm	1285 mm	14 mm	80 mm	20 mm	14.5mm	Yes
	K3C	31 mm	2040 mm	14 mm	80 mm	20 mm	14.5mm	Yes

Cable holder - hanging clip

The hanging clip allows a second cable support rail to be fitted allowing expanded organisation options. The hanger can be fitted to all version of cable hanging system using the appropriate aluminium tube.

Caswick Code	Vertical drop
SP208	150mm

