

Drawing Number: 1344

Product Code: SS710

Permutation :

Step 320 Ladder 150 28 x Grab B

Type of Test

TYPE TEST

Standard Tested to

EN13101:2002 (including Annex ZA1)

Step Specification

Step, 320mm CRS, 165mm nominal step projection or 150mm nominal rung projection. Location boss for Caswick stringer. For knocking into Caswick inserts previously cast into concrete rings or chambers.

Product Image

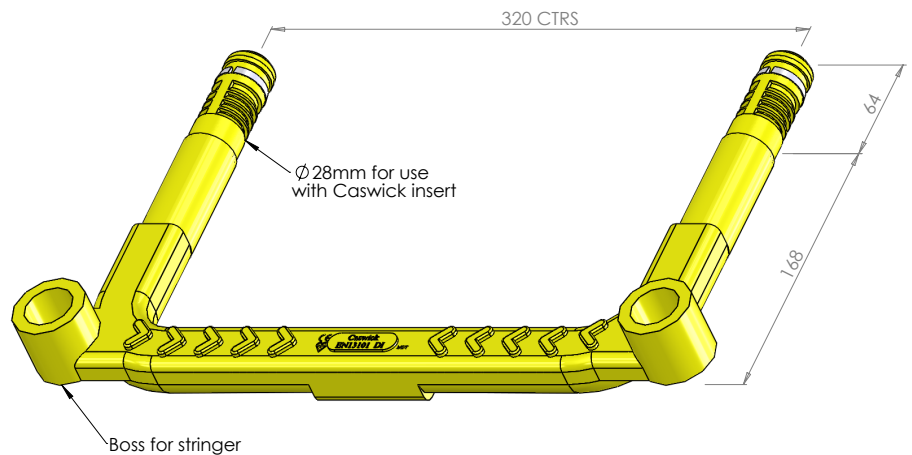

Approved by

Name: A. Turner
Signature: *A. Turner*
Position: Technical Manager
Issue date: 11th September 2014

The results in this test report apply only to the samples tested, using the method tested as detailed in this report. This test report does not indicate certification or approval of any product to any standard. This report may not be used to advertise any product without written consent from the Managing Director of Caswick Ltd. Caswick Ltd have to right to refuse the publication of this report to any person(s) without giving reason. Caswick reserve the right to change the information in this report at any time.

All test results given in this document are taken from a random step sample. The step is picked at random from normal production and tested in accordance with standard EN13101. Although routine random sample testing is carried out to ensure our products meet the highest standard, due to variations beyond our control the results given here may vary slightly to the product supplied to you. All steps will comply with EN13101.

Content	Product Overview	Page 1
	Intended Use	Page 1
	Product Drawing	Page 2
	Materials	Page 3
	Type	Page 3
	Typical Results:	
	Dimension Check	Page 4
	Limit of Insertion	Page 5
	Surface Condition	Page 5
	Corrosion Resistance	Page 5
	Twist Test	Page 5
	Vertical Load Test	Page 6
	Pullout Test	Page 8
	Impact Test	Page 8
	Plastic Integrity	Page 8
	Encapsulation Thickness	Page 9
	Marking	Page 10

Product Overview	320mm centres
	165mm nominal step projection
	150mm nominal rung projection
	Bright colour
	Side plate (boot stop)
	Boss for locating Caswick stringer.

Intended use	Incorporating into concrete structures. Fitting methods; - Knocking into Caswick inserts previously cast into concrete rings or tanks
---------------------	--

Product Drawing

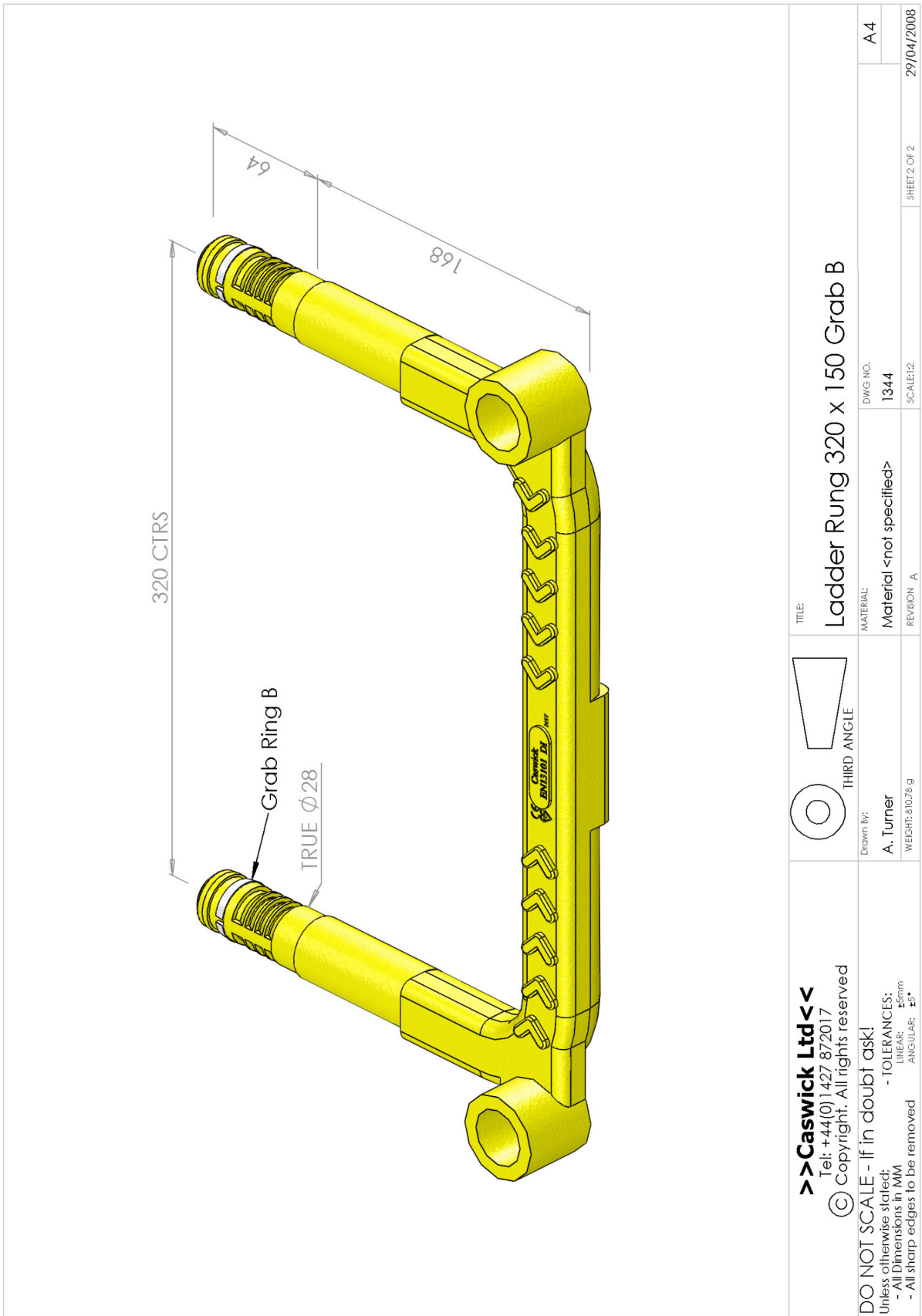

>> Caswick Ltd <<
Tel: +44(0)1427 872017
© Copyright. All rights reserved

DO NOT SCALE - if in doubt ask!
Unless otherwise stated:
- All Dimensions in MM
- All sharp edges to be removed
- TOLERANCES:
LINEAR: ±0.07mm
ANGULAR: ±5°

Materials

Section 4.2

Where appropriate the step materials shall conform to the following;

Category	Type	Required Standard	Actual Standard
	Steel	Steel to EN 10025 or ENV 10080:1995 or current equivalent	EN10305
		Stainless steel to EN10088-1 or EN10088-3 grade X6CrNiTi18-10 or better	Special Order
Plastics	Polyethylene	Minimum density 0.935 g/cm ³ as tested in ISO 1183	N/A
	Polypropylene	Polypropylene Copolymer	PP Block Copolymer High Impact

EN 13101:2002 Type

Requirement – Section 4.3.1

Requirement

Steps shall be one of the following types;

Type A – Circular tread without patterned surface, without upstand

Type B – Circular tread without patterned surface, with upstand

Type C – Any shape tread with patterned surface, without upstand

Type D – Any shape tread with patterned surface, with upstand

Result

The step is a type D

EN 13101:2002 Dimension Check Requirement – Section 4.3.2

Requirement When measured at the points shown on the diagram below, the dimensions must be within the range set in the table below.

Result

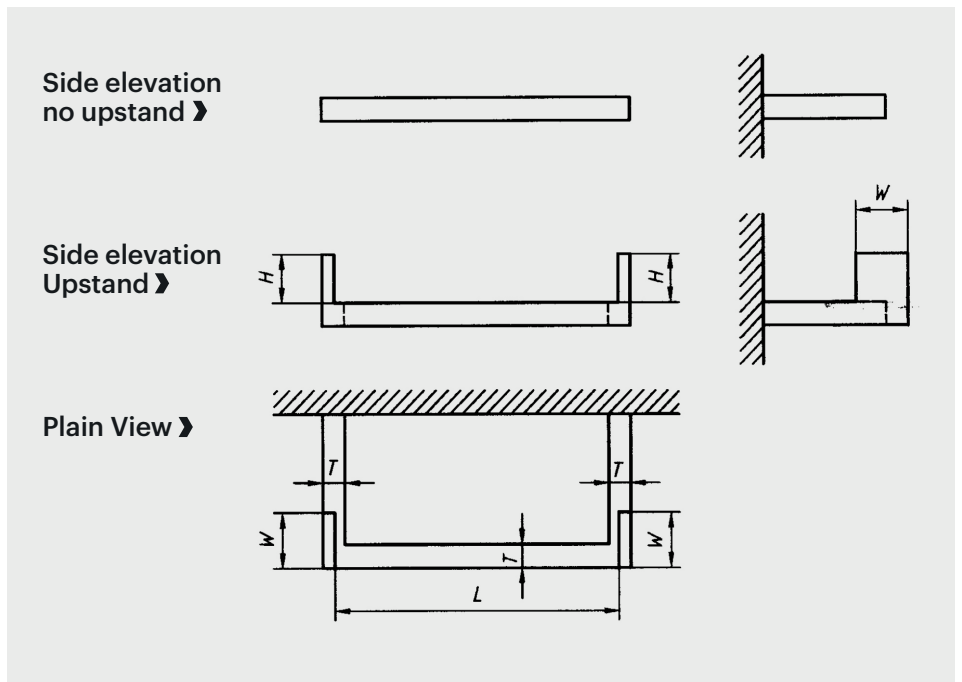

Dimension	Specified (mm)		Actual (mm)
	Single	Double	
Width of tread (T)	>20	>20	30
Length of tread (L)	>145	>250	320
Stand off distance (P)	>120	>120	165
Upstand (H)	5 to 20	>= 20	22
Upstand (W)	>=25	25 to 100	40

Note: Dimensions H & W are requirements of step type B & D only

Is the upstand on double steps within 70mm from the front of the tread? Yes No

EN 13101:2002 Limit of Insertion: Requirement – Section 4.3.3

Is the depth of insertion defined by a change in section or mark?

Yes No

EN 13101:2002 Surface Condition: Requirement – Section 4.3.4

Is the step free from visible defects, protrusions and sharp edges?

Yes No

EN 13101:2002 Corrosion Resistance: Requirement - Section 4.3.5

Material	Requirement	Sample
Steel	Galvanized to EN ISO 1461	
	Plastic Encapsulation	Yes

EN 13101:2002 Twist test: Requirement – Section 4.3.6
Procedure – Annex A

Requirement:

When supported on pins in three locations, the centre of the tread and at each tail, the variation in height along the length of the tread shall not vary more than 5mm for a double step and 3mm for a single step.

Position	Max Allowable	Gap (mm)
Left Quarter		19.9
Centre		20.0
Right Quarter		20.1
Range	3mm Single 5mm Double	0.2

EN 13101:2002 Vertical load test: Requirement – Section 4.3.7
Procedure – Annex B

Requirement: When loaded at the centre of the tread vertically down, the step must not deflect more than 10mm under a load of 2kN and return to within 2mm once the load is released. A load of 4kN must then be applied, once this load is released the step deflection must return to within 10mm

Results: **LOAD AT A RATE OF 1kN/min TO 3kN/min**

Procedural Event	Deflection (mm)	
	Actual	Max Allowable
Zero Dial Gauge and Load cell		
Load to 0.5kN	1.11	
Load to 1.0kN	2.27	
Load to 1.5kN	3.76	
Load to 2.0kN and hold for 60 seconds	6.37	10mm
Return to 0.0kN and allow to settle	1.05	2mm

Zero Dial Gauge and Load cell		
Load to 0.5kN	1.13	
Load to 1.0kN	2.28	
Load to 1.5kN	3.55	
Load to 2.0kN	4.82	
Load to 2.5kN	6.27	
Load to 3.0kN	8.49	
Load to 3.5kN	11.81	
Load to 4.0kN and hold for 60 seconds	24.36	
Return to 0.0kN and allow to settle	9.02	10mm

Did the plastic fracture? Yes No

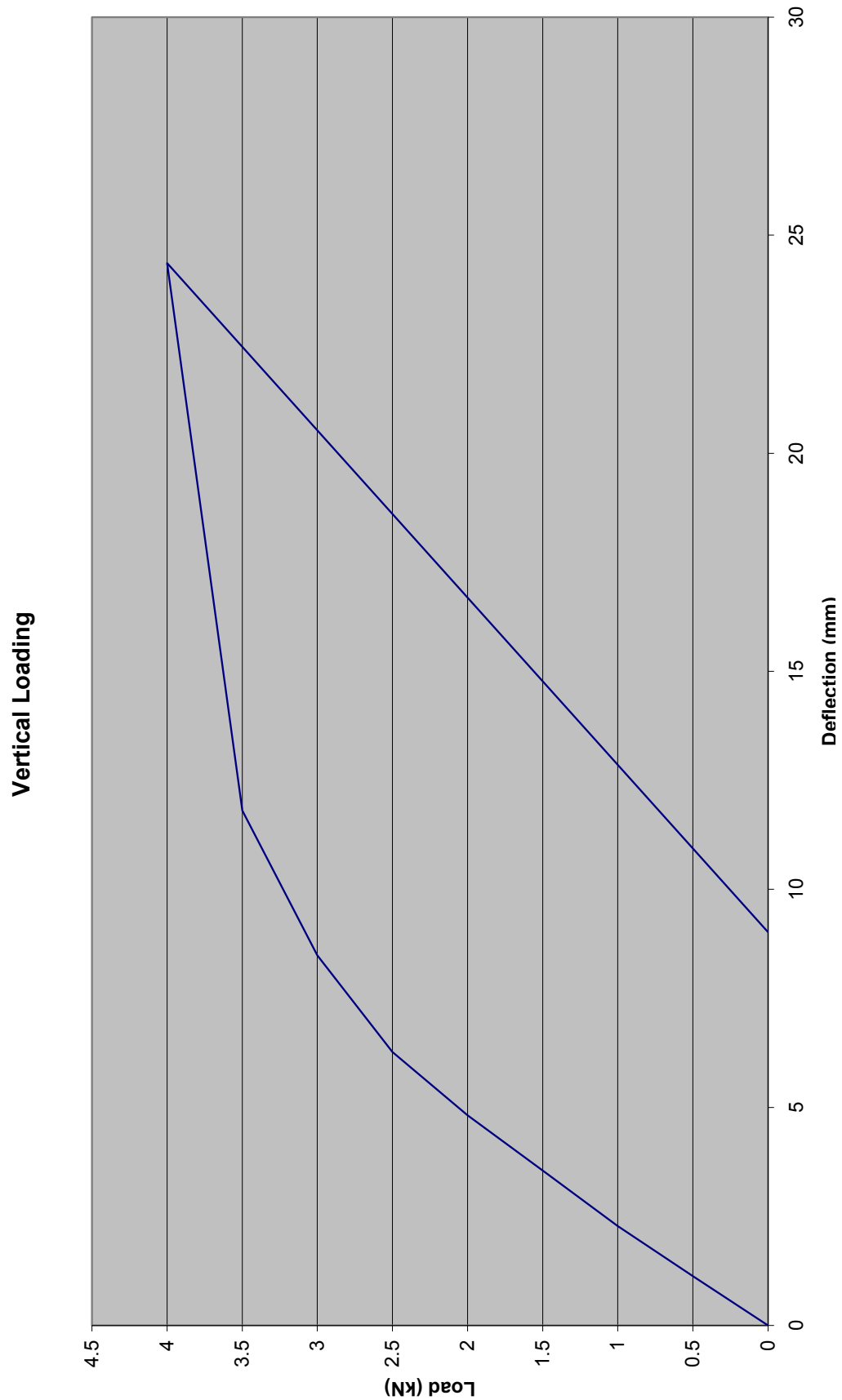

EN 13101:2002 Pullout test: Requirement – Section 4.3.9
Procedure – Annex D

Requirement: The step must withstand a force of 5kN applied in the horizontal plane away from the fixing for 60 seconds without sign of failure.

Results:

Procedural Event	Load (kN)
Load to 5.0kN in no more than 60 seconds without shocking the step. Hold for 60seconds.	
Load at failure or load sustained	>5kN for 60s

Note: Product tested with Caswick insert SP139

EN 13101:2002 Impact test: Requirement – Section 4.3.10
Procedure – Annex E

Requirement: A step conditioned at 20°C for 4 hours must withstand a 20kg mass dropped on its tread from a height of 1 meter without signs of failure. After impact the step must provide an electrical resistance of at least 1MΩ at 500v when immersed in a water based solution for 30 minutes.

Results: Step held at 20°C for 4 hours.

Visual assessment of step after impact:
No cracks in plastic

EN 13101:2002 Plastic Integrity test after Impact:

Reading 1 (M Ohms): >999
Reading 2 (M Ohms): >999

EN 13101:2002 Plastic Integrity test: Requirement – Section 4.3.11
Procedure – Annex F/G

Requirement: The step must provide an electrical resistance of at least 1MΩ at 500v when immersed in a water based solution for 30 minutes.

Results: Reading 1 (M Ohms): >999
Reading 2 (M Ohms): >999

EN 13101:2002 Encapsulation

Thickness Test:

Requirement – Section 4.3.12

Procedure – Annex H

Requirement:

When cut at the 5 positions shown below, the encapsulation thickness must be 2.5mm or over.

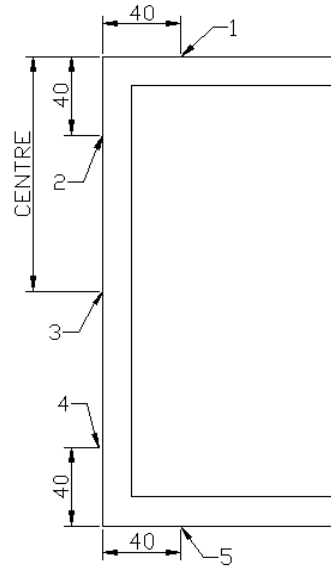

	Thickness of Cover (mm)	
	Min Specified	Actual
Point 1	2.5	4.5
Point 2	2.5	4.2
Point 3	2.5	4.3
Point 4	2.5	4.4
Point 5	2.5	4.6

Marking:

Section 6

The following shall be visible after installation;

Marking Requirements

Present?

"EN13101"

Yes No

Manufactures Identification

Yes No

Material Code (see below)

Yes No

Type and class

Yes No

Material	Solid	Tubular
Mild Steel	MSS	MST
Stainless Steel	SSS	SST

Material codes - Table 3 from EN 13101:2002

**Additional marking on this product
(for information purposes only);**

CE Mark next to manufacturers name?

Yes No

Third party certification body
(BSI Kitemark)?

Yes No