

Description:

Steps are designed to provide safe access to underground manholes and man entry chambers. They are manufactured from virgin polypropylene copolymer plastic and reinforced with structural carbon steel. This provides high strength with excellent corrosion resistance. The steps are manufactured in high visibility colours with a slip resistant design.

Inserts are a plug which is cast into concrete manhole ring or underground structure at the time which they are manufactured. After the concrete has hardened and been de-moulded the steps are hammered into the inserts to provide access to the chamber. There are several advantages to this;

- › Can be use in both wet cast and dry cast manufacturing processes
- › Simplifies mould or shuttering design
- › Decreases stock of finished units held as the steps only need to be fitted at the time of dispatch
- › Increases range of steps that can be offered, for example, ladder steps

The following steps are compatible with Caswick inserts, for more details on the Caswick insert range see the Caswick insert brochure.

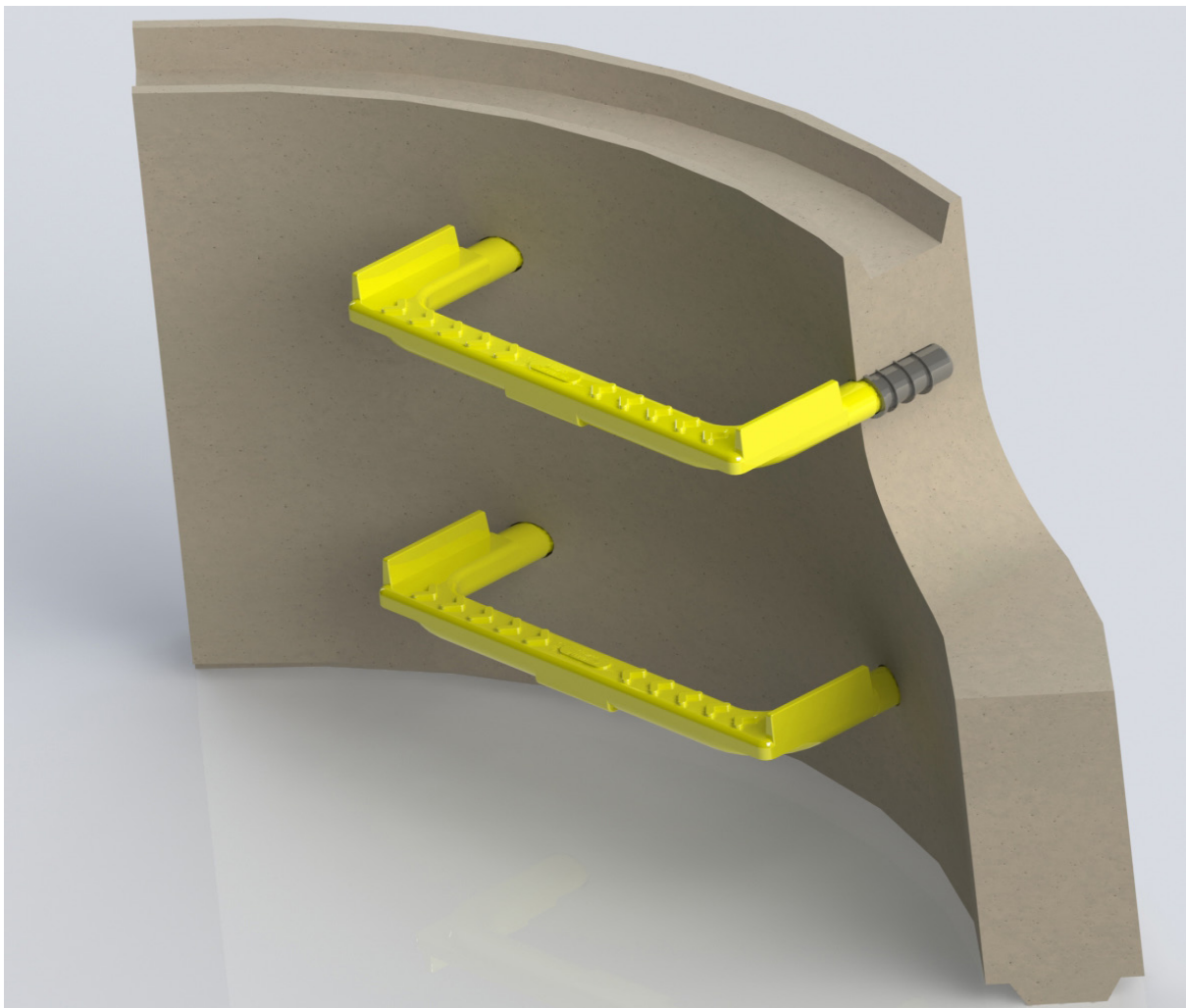

## SS230

- › Step with 320mm centres
- › Plain round end
- › 120mm projection
- › Boot stop
- › High grip tread
- › Compatible with caswick handhold
- › Kitemarked and CE marked to EN13101

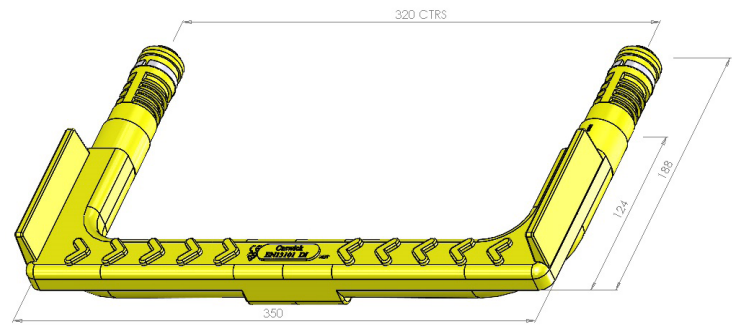

## SS259

- › Step with 320mm centres
- › Plain round end
- › 165mm projection
- › Boot stop
- › High grip tread
- › Compatible with caswick handhold
- › Kitemarked and CE marked to EN13101

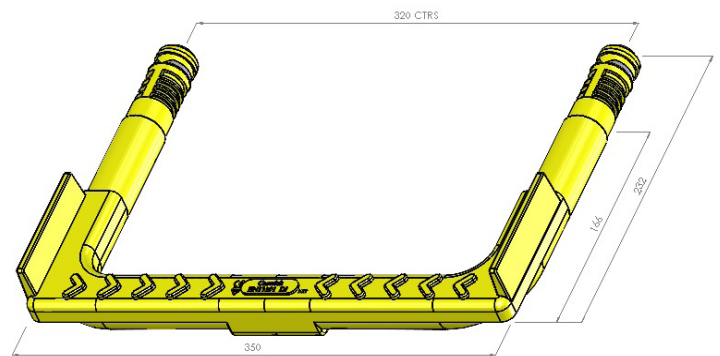

## SS710

- › Integrated ladder with 320mm centres
- › Use with Caswick stringer
- › Plain round end
- › 150mm ladder projection
- › Boot stop
- › High grip tread
- › Compatible with caswick handhold
- › Rung Kitemarked and CE marked to EN13101
- › System approved to WRc PT/385/1015-AS

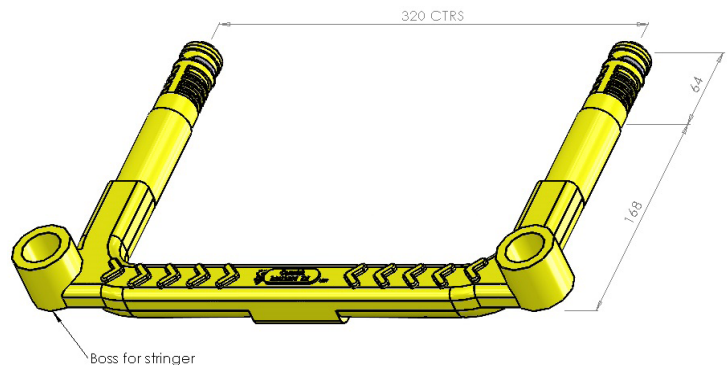

## SS700

- › Integrated ladder with 320mm centres
- › Use with Caswick stringer
- › Plain round end
- › 200mm ladder projection
- › Boot stop
- › High grip tread
- › Compatible with caswick handhold
- › Rung Kitemarked and CE marked to EN13101
- › System approved to WRc PT/385/1015-AS

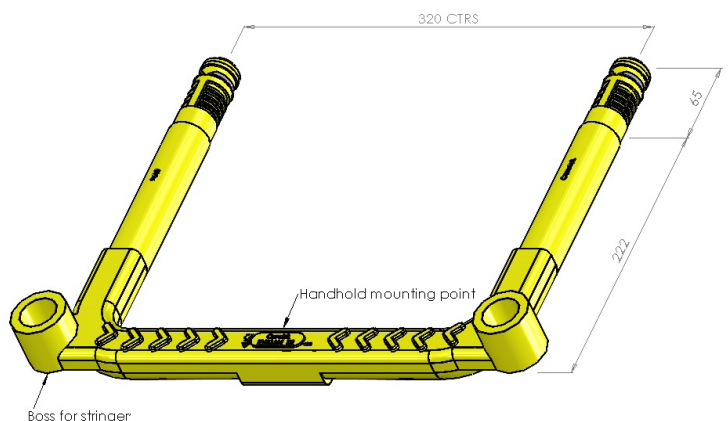

## S3007Y

- › Step with 300mm centres
- › Plain round end
- › 120mm projection
- › Boot stop
- › High grip tread
- › Compatible with caswick handhold
- › Kitemarked and CE marked to EN13101

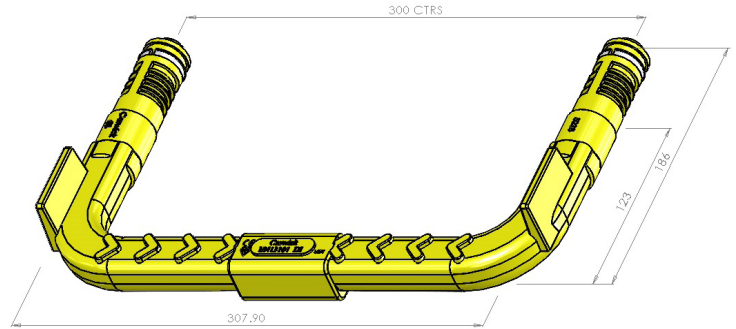

## S3005Y

- › Step with 300mm centres
- › Angular flanged end
- › 120mm projection
- › Boot stop
- › High grip tread
- › Compatible with caswick handhold
- › Kitemarked and CE marked to EN13101

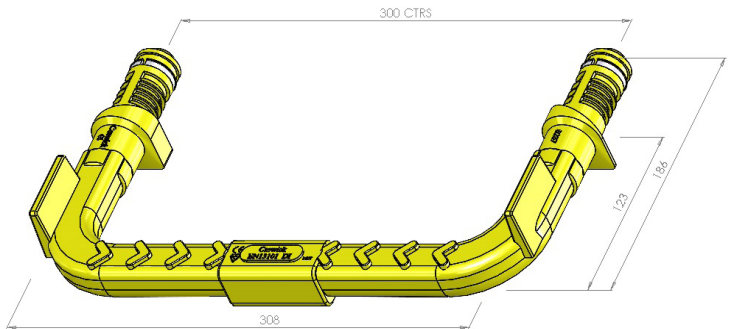

## S3018Y

- › Step with 300mm centres
- › Plain round end
- › 150mm projection
- › Boot stop
- › High grip tread
- › Compatible with caswick handhold
- › Kitemarked and CE marked to EN13101

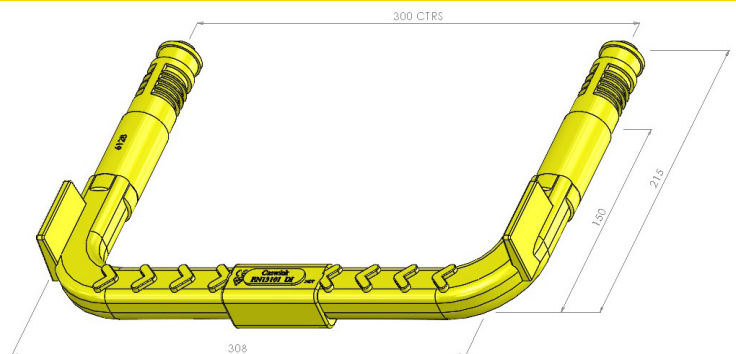

## S3017Y

- › Step with 300mm centres
- › Flat flanged end
- › 150mm projection
- › Boot stop
- › High grip tread
- › Compatible with caswick handhold
- › Kitemarked and CE marked to EN13101

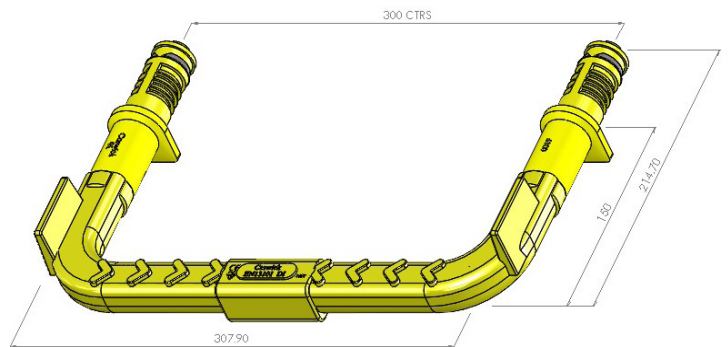

## S3016Y

- › Step with 300mm centres
- › Plain round end
- › 165mm projection
- › Boot stop
- › High grip tread
- › Compatible with caswick handhold
- › Kitemarked and CE marked to EN13101

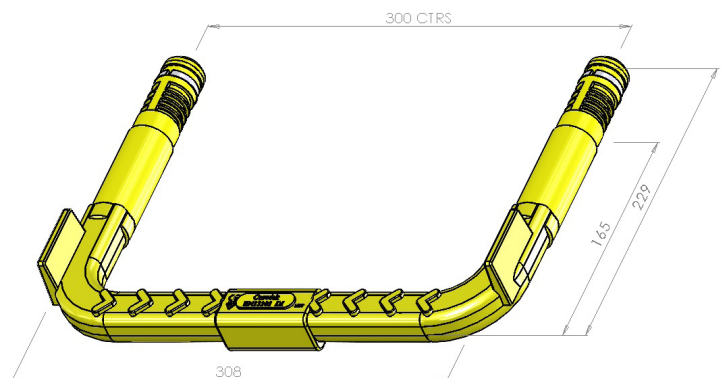

## S3307Y

- › Step with 330mm centres
- › Plain round end
- › 120mm projection
- › Boot stop
- › High grip tread
- › Compatible with caswick handhold
- › Kitemarked and CE marked to EN13101

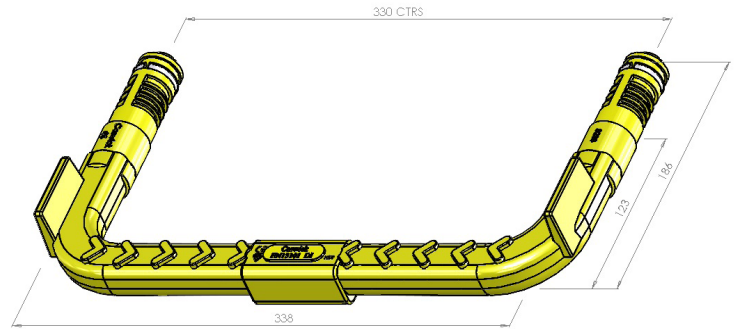

## S3305Y

- › Step with 330mm centres
- › Angular flanged end
- › 120mm projection
- › Boot stop
- › High grip tread
- › Compatible with caswick handhold
- › Kitemarked and CE marked to EN13101

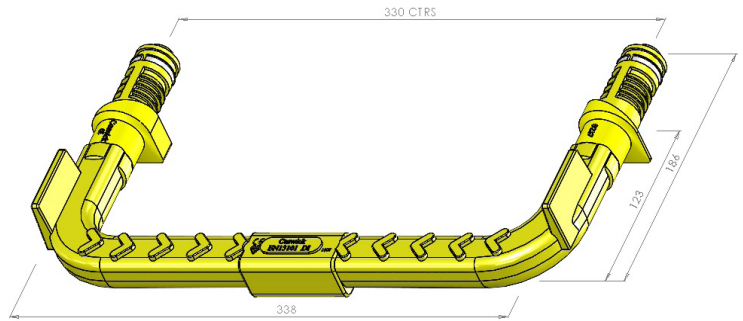

## S3317Y

- › Step with 330mm centres
- › Flat flanged end
- › 150mm projection
- › Boot stop
- › High grip tread
- › Compatible with caswick handhold
- › Kitemarked and CE marked to EN13101

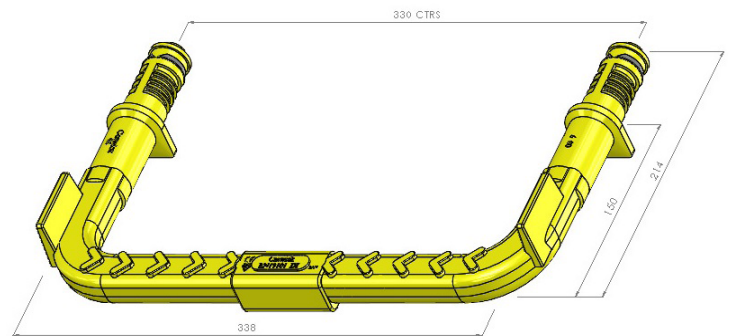

## S3318Y

- › Step with 330mm centres
- › Plain round end
- › 150mm projection
- › Boot stop
- › High grip tread
- › Compatible with caswick handhold
- › Kitemarked and CE marked to EN13101

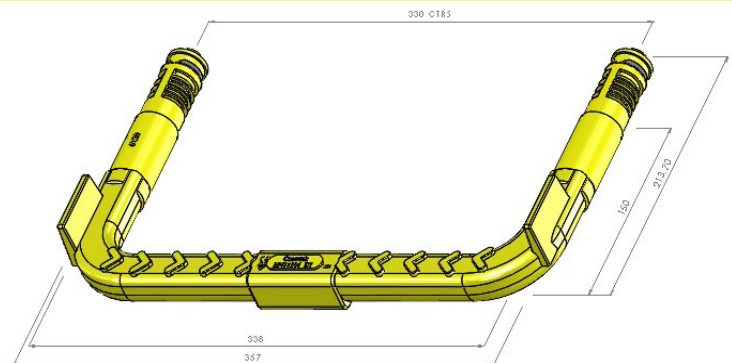

## S3316Y

- › Step with 330mm centres
- › Plain round end
- › 165mm projection
- › Boot stop
- › High grip tread
- › Compatible with caswick handhold
- › Kitemarked and CE marked to EN13101

