



Grade Ring Forming Systems



Wetcast Forms Customized to Your Specifications

- Round
- Square
- Rectangular

Heavy steel construction designed for strength, durability and performance

Afinitas is known for bringing together the top engineering and manufacturing expertise in the industry to build best-in-class precast forming systems. Our wide range of quality products are backed by knowledgeable and responsive customer sales and manufacturing team members who are there to assist you throughout the life of your form. And to that point, our forms are built to last. We combine heavy-duty steel with an innovative approach to manufacturing that will ensure we can help you take your business where you want to grow.

Wetcast formwork is a core competency of the Afinitas team. We have been trusted for decades to engineer forms for a wide variety of applications, including:

- Manhole Cone Forms
- Manhole Riser Forms
- Manhole Slab Top, Transition Slab, Base Slab Forms
- Box Forms
- Flared End Forms
- Battery Grade Ring Forms
- Manhole Joint Rings



Manhole Cone Form



Box Form



Grade Ring Form



Afinitas is your source
for Wetcast Forming Systems.

Contact our team at
+1 641-394-4111
or email rfq@afinitas.com

Afinitas offers a complete range of single pour and battery-style wetcast grade ring forming systems designed to help you maximize efficiency in your concrete grade ring adjustment systems.

Whether you require round (manhole grade ring forms) or rectangular (catch basin grade ring forms), Afinitas has a system that can withstand the harshest storm and sanitary sewer conditions.

Single Pour Grade Ring Form

Single pour grade ring forms are available as two-piece or optional one-piece forms, and come standard with a collapsible core. The system also includes a flat pallet that is flame-cut or for an option, machined.

The Afinitas Advantage

- Heavy steel construction designed for strength, durability and performance
- Diameters 24" through 48"
- Mechanical collapsing inner core
- Variable height adjustments
- Two-piece form design with toggle clamps, seam bars and alignment pins

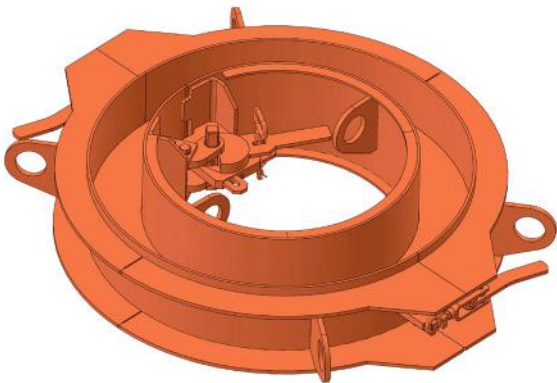

Two-piece forms



OPTION: One-piece form with ganged latch

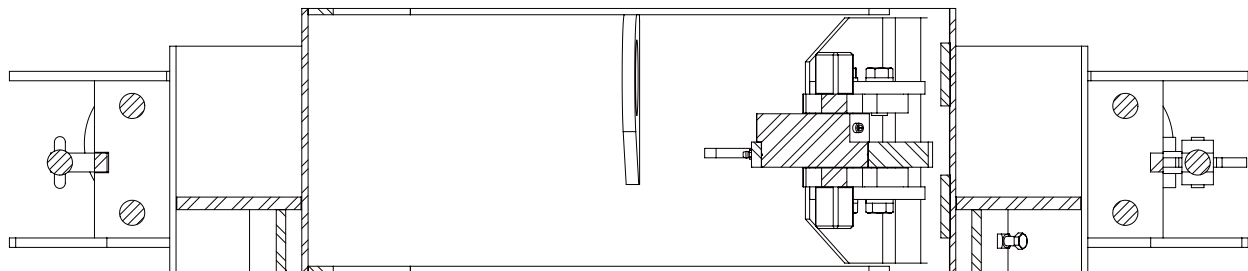

Why Choose a Battery Ring Form?

- Multiple grade rings can be made all in one pour
- Standard form length of 72" long
- Three-piece, fold-open form design with toggle clamps, seam bars and alignment pins
- Manual collapsing core

The Afinitas Advantage

- Heavy steel construction designed for strength, durability and performance
- Diameters 24" through 48"
- Mechanical collapsing inner core
- Predetermined grade ring thickness adjustments of: 2", 3", 4", 6", 8" & 12"

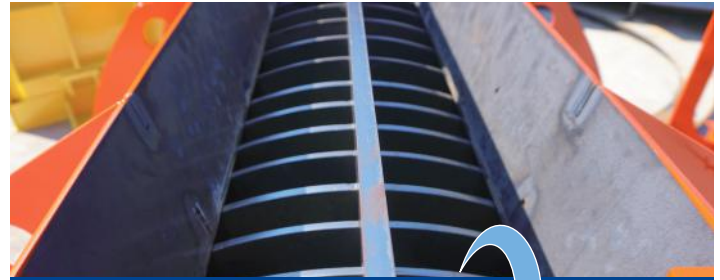

Divider alignment plate



Three-piece fold open form

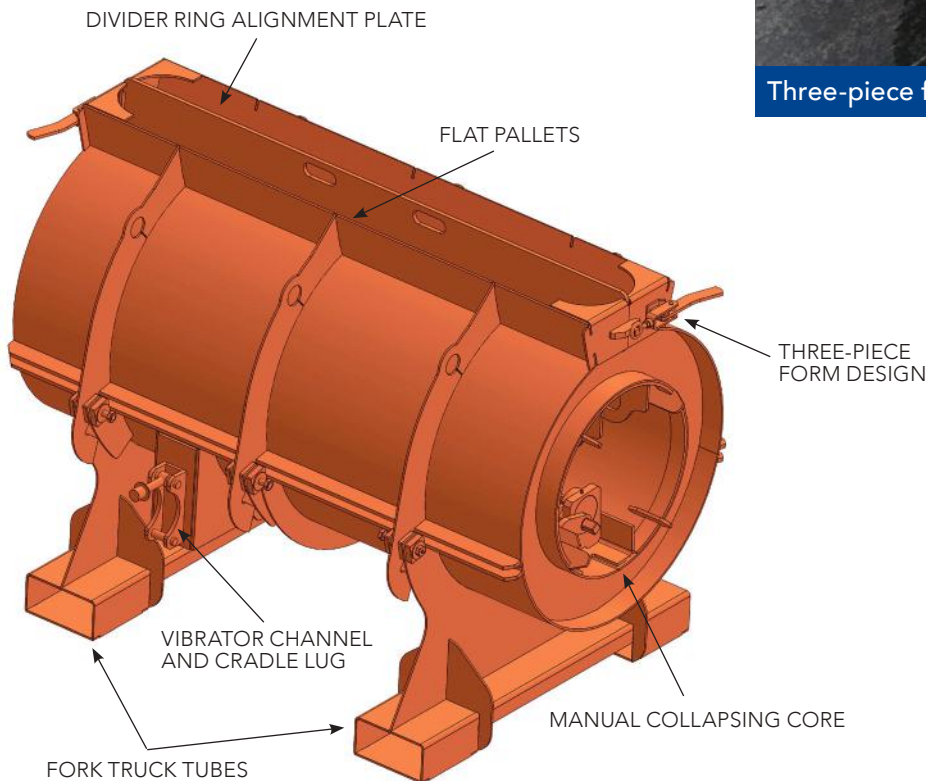

Special short length, three-piece fold open form

Battery Grade Ring Forms Options

Roller Table Benefits:

- You can manually collapse the core and roll the core on the table. This reduces crane or fork truck picks.
- Reduced core handling for less core damage.

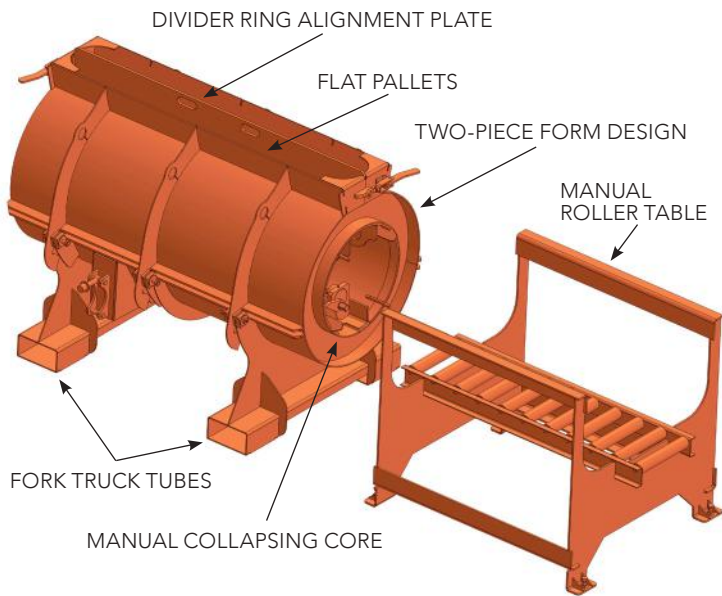

Two-piece option



OPTION: Two-piece form (top form half lifts off using an overhead hoist)

See our Battery Grade Ring Form in action.



NextGen Quick Strip Battery Grade Ring Form

Why choose a NextGen form?

- Manually collapse the core and roll the core outward. No need for an overhead crane or fork truck.
- Reduced core handling for less core damage.
- Manually open/close the outer form.
- Lift the concrete products up and out of the form using an overhead hoist or fork truck.

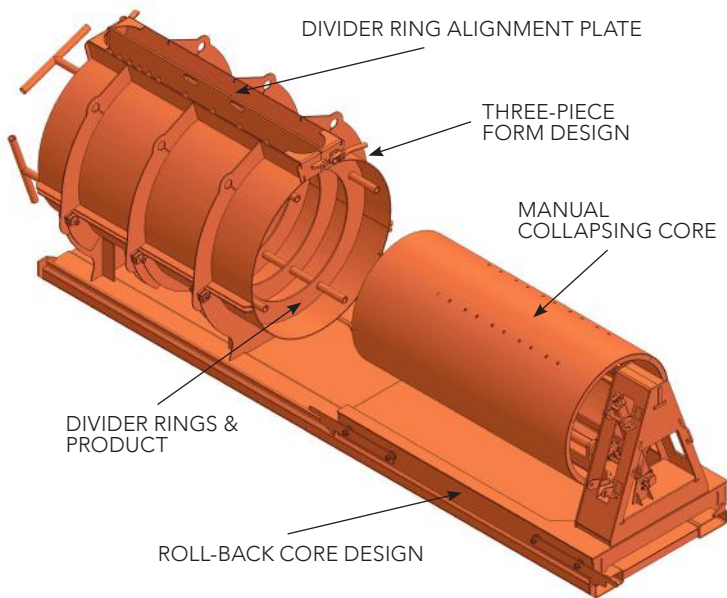

Single Pour Square and Rectangular Forms

These custom-designed forms are used to create a wide variety of grade rings for utility boxes, drainage channels, vaults and more.

The Afinitas Advantage

- Heavy steel construction designed for strength, durability and performance
- Mechanical collapsing inner core
- Two-piece form design with toggle clamps, seam bars and alignment pins
- Various sizes are available
- Variable height adjustments



Two-piece form

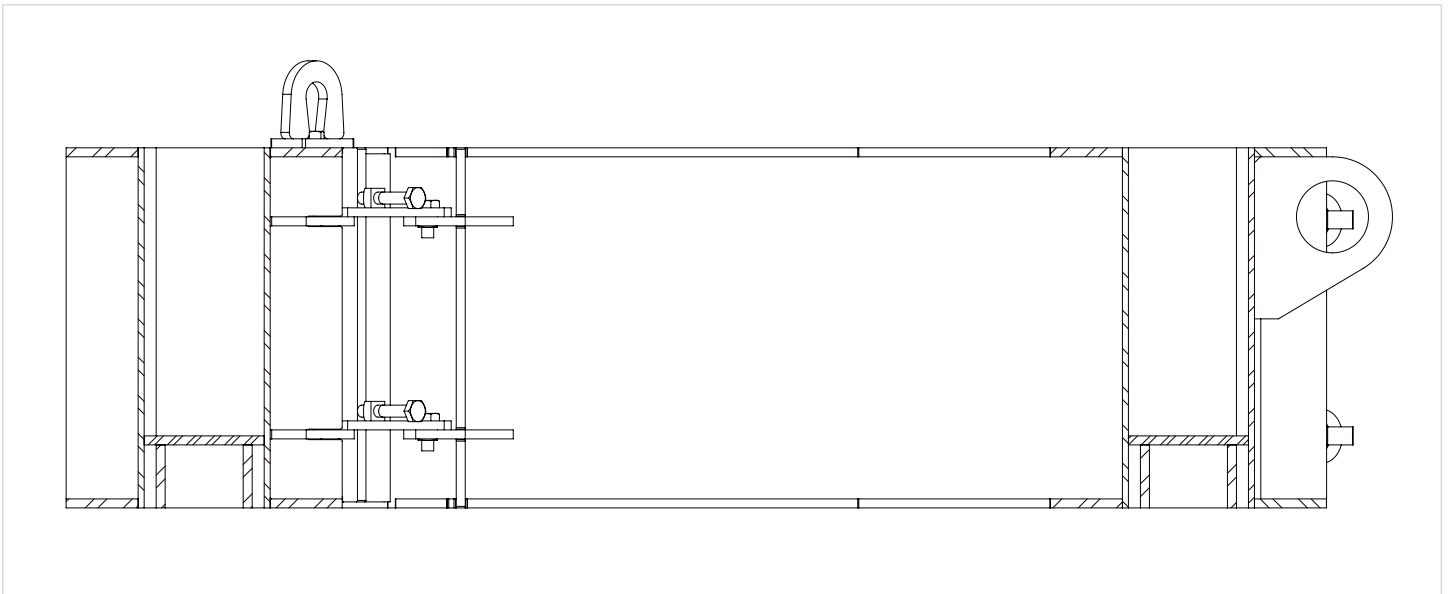
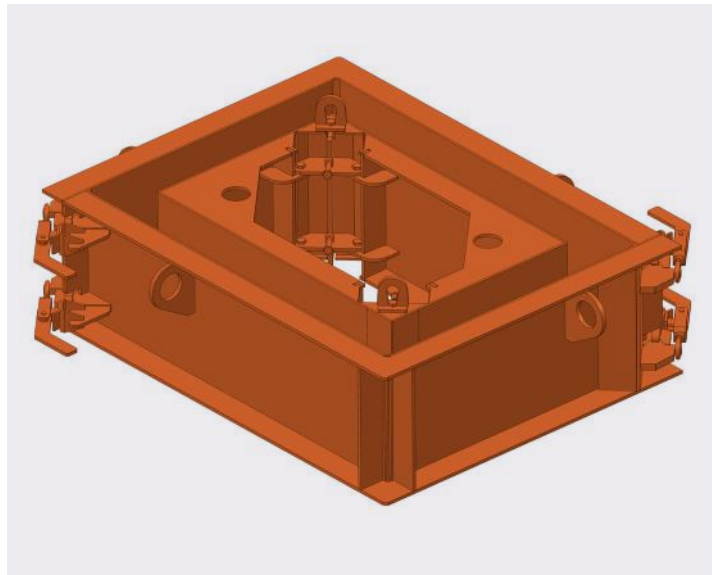

Special Battery Forms

Round OD with Square or Rectangle ID

The Afinitas Advantage

- Heavy steel construction designed for strength, durability and performance
- Multiple grade rings can be made all in one pour
- Standard form length of 72" long
- Three-piece, fold-open form design with toggle clamps, seam bars and alignment pins
- Mechanical collapsing inner core
- Predetermined grade ring thickness adjustments of: 2", 3", 4", 6", 8" & 12"

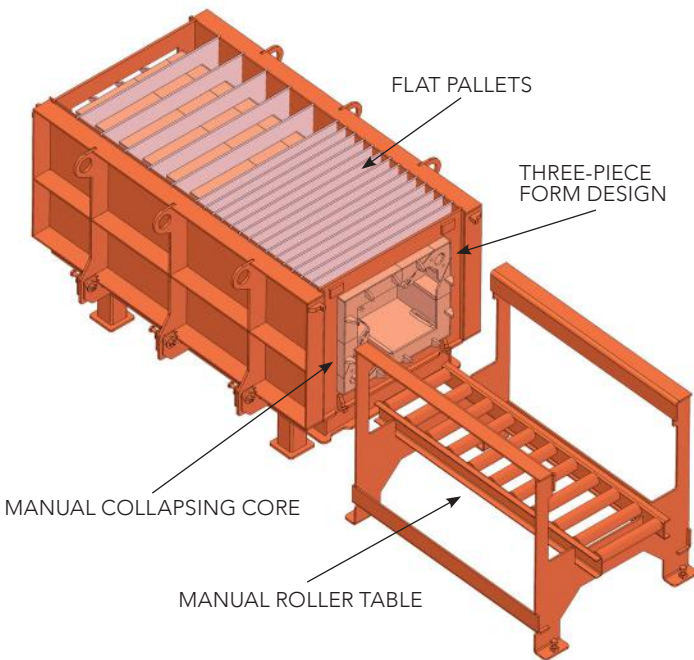

Special short length, three-piece fold open form



**Need
concrete
accessories?**

See our selection at
afinitas.com/accessories.



Grade Ring Section Views

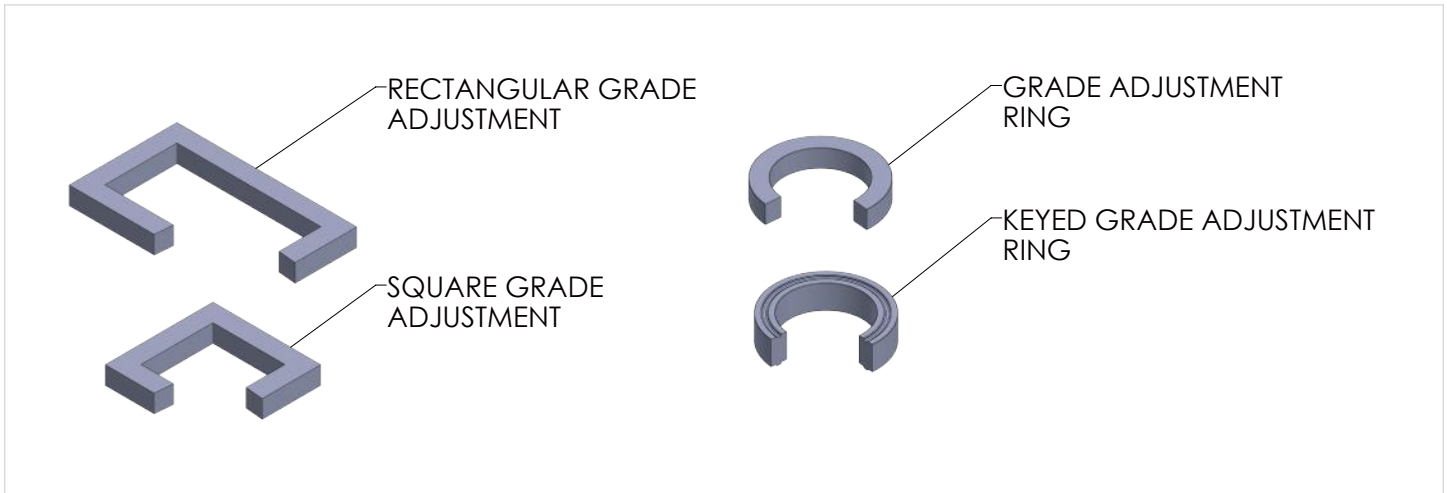

Introducing SmartJax™ A revolutionary way to firmly stool up pallets inside concrete forms

Our **patent-pending SmartJax™** adjustable support stand offers many advantages over existing pallet support systems:

Simply Genius! You will love the speed and convenience of having a single unit to support and secure your pallet. Stand and magnets all-in-one.

Safe – say goodbye to the splintering and unreliability of using wood pieces, PVC or hollow core concrete traditionally used as supports.

Strong – our stand is built to last as a heavy steel fabricated weldment.

Speedy – multiple hole locations in the support tube make pin-facilitated height adjustment quick and easy.

Product Highlights

- 8000 pound capacity**
- 12" overall height with adjustment up to 18" tall in 1" increments, making it simple to size to your requirements
- 1000 pound on/off button base magnet for attachment to form sub-base
- Interchangeable leg tube heights

* Patent-pending.

** Depending on pallet design, a minimum of 3 to 4 SmartJax™ (or more) are to be used at all times to support a flat pallet, pallet support stool, joint forming pallet or any combination along with the concrete load.



SmartJax™ can be used on both box and round forms.

SmartConnect™ Cordless Hydraulic Power System for Collapsible Cores

Precast concrete forms with collapsible cores make it easier to remove the product from the form. However, powering up the hydraulics to retract and expand the core can be a hassle. Typically a large cart carrying a power unit, power cords and hoses must be wheeled to the form. The hoses must be attached to the hydraulics on the form, the unit must be plugged in and once the core moves, everything must be disconnected before the cart can move to the next form. This process not only takes time but it wastes time that could be spent working on multiple forms at once.

Introducing SmartConnect™ *

An Intelligent Bolt-On Power Unit for hydraulic collapsible cores. With SmartConnect™, you have a self-contained hydraulic power unit that is mounted directly on the form. There are no electric carts or cords. The unit is powered by a standard 20 volt - 1/2" drive cordless drill that uses the same hydraulics to operate the core to open and close.

Benefits of SmartConnect™

- **Save time — at least 10 mins. or more per form!**
 - No wheeling of carts around the plant
 - No hoses and cords to connect and disconnect
 - No more waiting — all you need is a cordless drill to operate the unit, allowing you to work on many forms at once
 - Ultimately, your strip-out and set-up will go faster
- **Increased Safety**
 - With no electrical cords strung throughout the plant, tripping hazards are reduced
 - Minimizes potential electrical shock hazards if water is present
- **Space Saver**
 - Eliminating the bulky cart means more open floor space in an already equipment-packed area
- **Flexible**
 - Works on AFINITAS forms up to 7' x 7' boxes and manhole form diameters up to 72"
 - Retrofit your existing forms or add to new AFINITAS form purchases
- **Quick Payback**
 - SmartConnect costs significantly less than a 110V hydraulic cart system
 - When you calculate the productivity gains and reduced safety risks, the system pays for itself in no time (in most cases 3 years or less).

* patent-pending technology



SmartConnect™ is mounted directly on the form to power the collapsible core hydraulics.



The self-contained unit is not dependent on any other equipment except a standard 20 volt - 1/2" drive cordless drill

Watch the SmartConnect™
Cordless Hydraulic Power
System Video



Afinitas brings you the industry's best formwork and a whole lot more.

Afinitas is the premier platform of precast concrete infrastructure equipment and services.

With decades of experience in the pipe and precast concrete markets, we provide manufacturers around the world with the gold standard in precast concrete product production equipment, highly engineered drycast and wetcast forms and a wide variety of concrete accessories.

Our combined strengths mean more concrete machinery engineering resources, manufacturing know-how and pipe and precast concrete industry experience is ready to help you create the ideal production systems for your infrastructural concrete product needs.

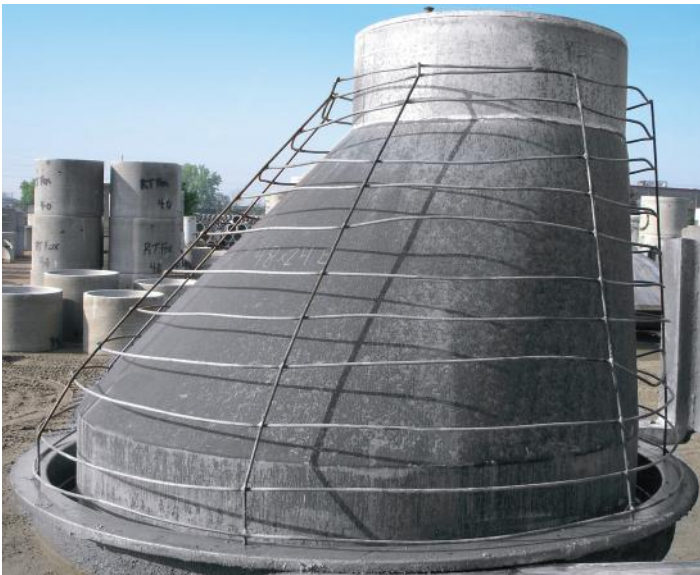

Cone Cages from Haala Industries brand



Butt Welded Hoops for Grade Rings, Risers and Cones from our Haala Industries brand.



SmartSet™ Curing Systems

- Next-gen and basic direct-fired steam generators
- Controls and airflow systems
- Misting and drying components
- Kilns, piping, moving floors
- Dedicated tech team and service

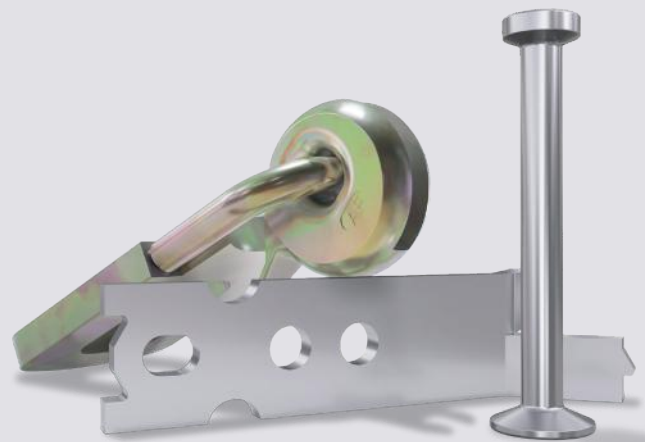

Lifting Anchors, Fixation Inserts and other precast accessories



Grade Ring Forming Systems

Equipment & Automation



Concrete Accessories



Forming Systems

Intelligent Infrastructure Solutions
Visit www.afinitas.com to learn more.

Afinitas Forming Systems Division

Iowa

928 W Milwaukee
New Hampton, IA 50659

Phone: 641-394-4111

Fax: 641-394-4542

rfq@afinitas.com

Ohio

1701 Moler Road
Columbus, OH 43207

Phone: 614-444-2184

rfq@afinitas.com



Intelligent Infrastructure Solutions

Afinitas is a global, comprehensive and customer-oriented equipment, automation, forming and accessories platform for precast concrete and infrastructural products.

Afinitas Forming Systems Division:

928 W. Milwaukee | New Hampton, IA 50659 USA | +1 641-394-4111 | rfq@afinitas.com | www.afinitas.com